



THERMAL DIFFERENTIAL FLOW & LEVEL SWITCHES

Kenco's Thermal Differential Switches are designed for a wide range of flow and level applications. These switches can be used to detect either the overall liquid level or a liquid – liquid interface. They can also be used to detect a specific flow rate or a flow/no flow condition in liquids and gasses.

FEATURES

- Level and Interface detection
- Flow detection for Liquids and Gasses
- Fast Response Time
- No Moving Parts
- Temperature Compensation

APPLICATIONS

- Level detection
- Nitrogen Flow detection
- Low Flow Monitoring
- Liquid-Liquid Interface detection
- Foam-Liquid Interface detection
- Pump Protection
- Flare Systems

INDUSTRIES

- Chemical
- Petroleum
- Water / Wastewater
- Pharmaceutical
- Pulp & Paper
- Power
- Aerospace

PRINCIPLE OF OPERATION

The sensor consists of (2) Resistance Temperature Detectors (RTDs). One RTD measures the temperature of the fluid around the sensor. The other RTD is self-heated. This provides a temperature differential between the two RTDs.

In a Level application, the thermal conductivity of the liquid is higher than the gaseous layer above the liquid. When the RTDs make contact with the liquid, there is a cooling effect with the liquid absorbing the heat from the heated RTD. This reduces the temperature differential between the two RTDs, and causes the relay to change state. When the liquid level drops below the sensor, the temperature differential increases, causing the relay to reset. This will also work in a liquid-liquid interface when the two liquids have different thermal conductivity (ex. oil and water).

In a Flow application, there is a temperature differential during a no-flow or low-flow condition (the actual setpoint is adjusted during the calibration procedure). As the flow rate increases, the temperature differential between the RTDs decreases, causing the relay to change state. When the flow rate decreases, the temperature differential increases, causing the relay to reset.



ORDERING GUIDE

REQUESTED BY: _____ COMPANY: _____
 ADDRESS: _____ CITY: _____ STATE: _____ ZIP: _____
 PHONE: _____ FAX: _____ EMAIL: _____

<div style="border: 1px solid black; width: 100%; height: 20px; margin-bottom: 5px;"></div> <p>Model KTDL = Level Switch KTDF = Flow Switch</p>	<div style="border: 1px solid black; width: 100%; height: 20px; margin-bottom: 5px;"></div> <p>Process Connection 050 = 1/2" NPT 075 = 3/4" NPT 100 = 1" NPT 3A1 = 1 1/2" Sanitary RA1 = 1" 150# ANSI Flange RA2 = 2" 150# ANSI Flange RB1 = 1" 300# ANSI Flange RB2 = 2" 300# ANSI Flange LFS = Low Flow Sensor SPL = Special Connection</p>	<div style="border: 1px solid black; width: 100%; height: 20px; margin-bottom: 5px;"></div> <p>Sensor Material S6 = 316L SS S4 = 304 SS SL = 304L HB = Hastelloy-B HC = Hastelloy-C IO = Inconel 600 MN = Monel A2 = Alloy-20 SM = Special Material</p>	<div style="border: 1px solid black; width: 100%; height: 20px; margin-bottom: 5px;"></div> <p>Insertion Length 002.00 = Standard 002.50" - 120.00" = (Optional - KTDL) 002.50" - 012.00" = (Optional - KTDF)</p>
<div style="border: 1px solid black; width: 100%; height: 20px; margin-bottom: 5px;"></div> <p>Input Power 110 = 110Vac 220 = 220Vac 24D = 24Vdc 24A = 24Vac</p>	<div style="border: 1px solid black; width: 100%; height: 20px; margin-bottom: 5px;"></div> <p>Configuration LE = Integral Mounting RE = Remote Mounting</p>	<div style="border: 1px solid black; width: 100%; height: 20px; margin-bottom: 5px;"></div> <p>Options 00 = No Options RT = RTD Output LT = Live Tap CE = CE Approved EN = Extended Neck HT = *High Temp (850°F) MT = *Medium Temp (572°F)</p>	<p>XW = Explosion-proof Window CA = Additional Cable VI = Variable Insertion CB = Factory Calibration TO = Thermocouple Output TG = SS Tag TE = Sensor Installed in Tee *Remote Mounting Required</p>

Example Model Designation: KTDL-050-S6-002.00-110-LE-00

PRODUCT SPECIFICATIONS

DESCRIPTION		SPECIFICATIONS
Power Supply	AC	110Vac or 220Vac @ 50/60 Hz
	DC	24Vdc
Output	Relay	5A DPDT – Failsafe is field selectable
Temperature Range (Electronics)		-40°F to 140°F (-40°C to 60°C)
Temperature Range (Sensor)	Standard	-100°F to 390°F (-70°C to 200°C)
	Medium Temp.	-100°F to 572°F (-40°C to 300°C)
	High Temp.	-100°F to 850°F (-40°C to 458°C)
Pressure Range		Atmospheric to 3000psig
Operating Range (Flow)	Aqueous Liquids	0.01 to 2.5 feet/second
	Hydrocarbon Liquids	0.01 to 5.0 feet/second
	Gasses	0.1 to 500 feet/second
Response Time		0.5 to 5.0 seconds (media dependent)
Stability		<0.5% from calibrated setpoint over a range of ±50°F
Repeatability		±1.0%

AGENCY APPROVAL

AGENCY	MODELS	PROTECTION METHOD	SPECIFICATIONS
CSA	KTDL-X-X-X-X-X KTDF-X-X-X-X-X	Explosion-proof	Explosion-proof for: Division 1 Class I - Groups B, C, D; Class II - Groups E, F, G; Class III

APPLICATION EXAMPLES

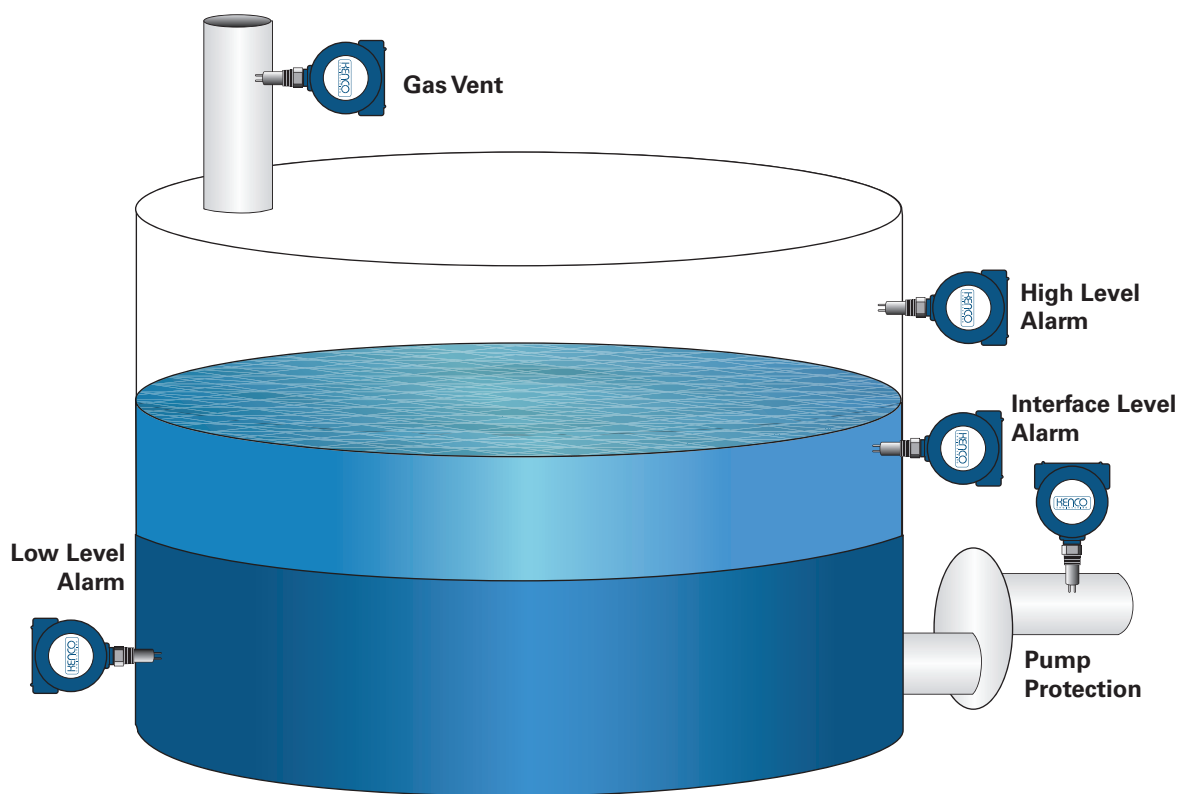

SPECIAL SENSORS

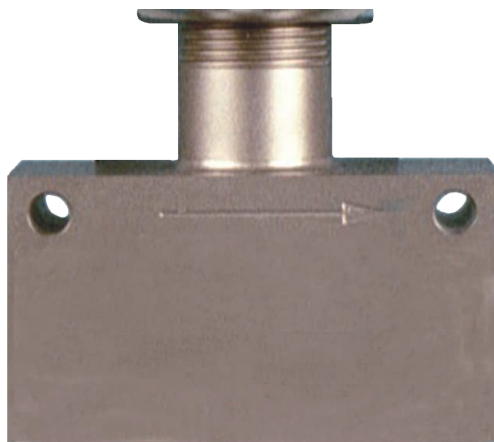

LOW FLOW SENSOR

- Developed for low flow gas and liquid applications where reliability and durability are mandatory
- Very low internal volume so that sample times are short and system response remains fast
- All welded stainless steel construction
- ¼" Female NPT process connections
- Operating temperature range: -100°F to 392°F

SANITARY SENSOR

- 3-A Certified
- Designed for use in food, beverage, dairy, and pharmaceutical applications
- Standard insertion length is 2.5". Contact Kenco for custom lengths.
- Operating Temperature Range: -100°F to 392°F
- Maximum Working Pressure of 1500 psig

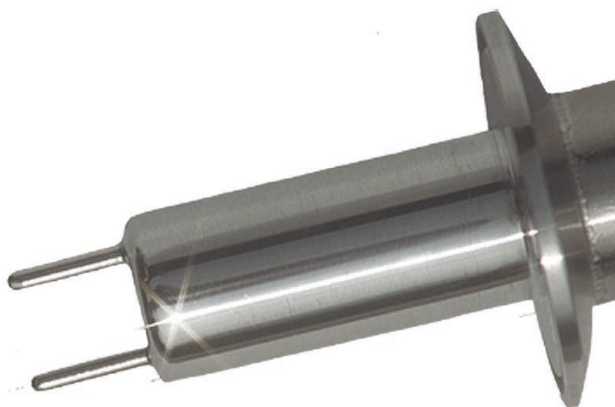

ADDITIONAL APPLICATIONS

Low flow monitoring in food processing plants

different lines are used to blend ingredients. If one of these lines becomes blocked, the product can be ruined. By monitoring the flow in each of the blending lines, a Kenco Model KTDF can prevent product loss.

Monitoring flow through heat exchangers

The Kenco KTDF flow switch can monitor the flow and activate a shut-down at a specific low flow, or no flow condition in the exchanger.

Eye wash station monitoring

The Model KTDF can be used to monitor the condition of an eyewash station. When the station is used, a signal is sent to notify emergency medical personnel.

Diesel Fuel / Water Interface Detection

Over time, fuel tanks can accumulate a significant amount of water. This water reduces the capacity of the tank. A Kenco Model KTDL can be used to detect the water, turn on a pump to remove the water and shut off the pump to prevent pumping the diesel fuel.

Flare Systems

A Kenco KTDF flow switch can be used to detect which vessel is emitting to the flare line. It can also be used to activate the flare igniter when gas flow is present, or to detect if the flare does not ignite in the presence of gas flow.

DIMENSIONAL DRAWINGS

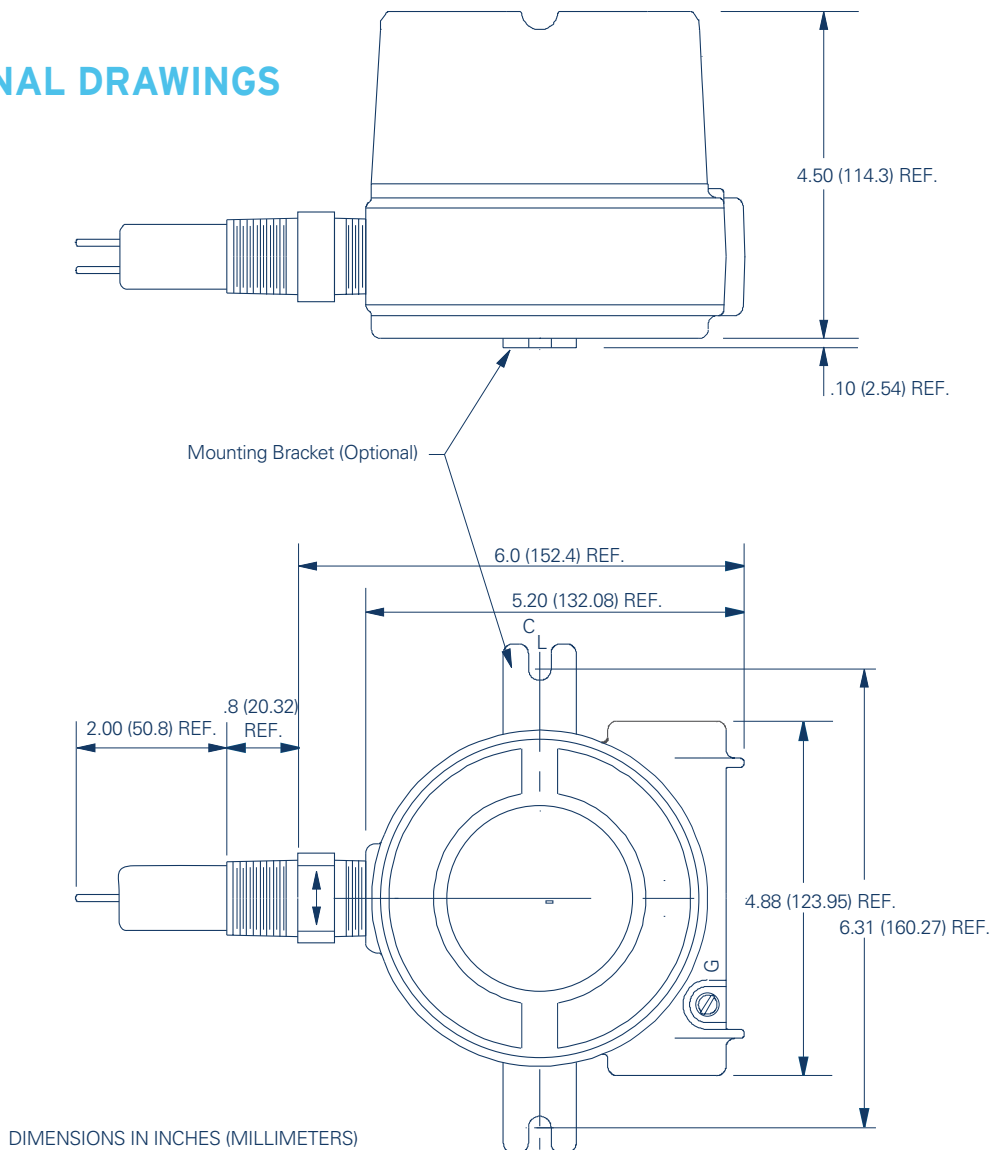

Represented by:

Kenco Sales Offices:

Headquarters

10001 E. 54th St.
Tulsa, OK 74146
phone 918.663.4406
fax 918.663.4480
www.kenco-eng.com
email: info@kenco-eng.com

Baton Rouge Office

11616 Industriplex, Suite 7
Baton Rouge, LA 70809
phone 225.755.1912
fax 225.755.1913
www.kenco-eng.com
email: kenco-la@kenco-eng.com

81904 8-4-23

