

KENCO ENGINEERING COMPANY

P.O. BOX 470426, TULSA, OK 74147-0426

PHONE: (918) 663-4406; www.kenco-eng.com; E-MAIL: info@kenco-eng.com

MODEL KPRL LOW PRESSURE REGULATOR INSTALLATION, OPERATION, AND MAINTENANCE INSTRUCTIONS

Principle of Operation:

The model KPRL is a direct acting pressure reducing regulator for use with natural gas, air, and a variety of other gasses. The outlet pressure is controlled by a diaphragm and adjustable spring that opens or closes the valve as the downstream flow demand changes. As the downstream flow demand decreases, the pressure downstream of the regulator will increase. This increase in pressure will be registered by the diaphragm and the diaphragm will compress the spring and move the seal closer to the orifice. On the other hand, an increase in flow demand will result in a decrease in downstream pressure. This decrease in pressure underneath the diaphragm will cause the spring force to move the seal further from the orifice and will allow more flow to pass through the regulator. With the correct spring and orifice combination, these opposing actions will equalize and maintain a constant pressure downstream while meeting the flow demand.

Features:

- Five different orifice sizes to accommodate a wide range of flow requirements.
- Orifice, seal holder, and valve stem all come Standard in 316 Stainless Steel.
- Wear items can be replaced without removing the body from the piping setup.
- Carbon steel body rated for 2000 psi of inlet pressure.
- Diaphragm and spring housing constructed of sturdy die cast aluminum.
- Regulator can conveniently function with diaphragm and spring housing in multiple orientations.
- Protective cap allows for tamper resistant pressure settings.
- 10 to 95 psi utility spring available.
- Wetted pressure retaining components of the 1" and 2" NPT models comply with NACE MR0175.

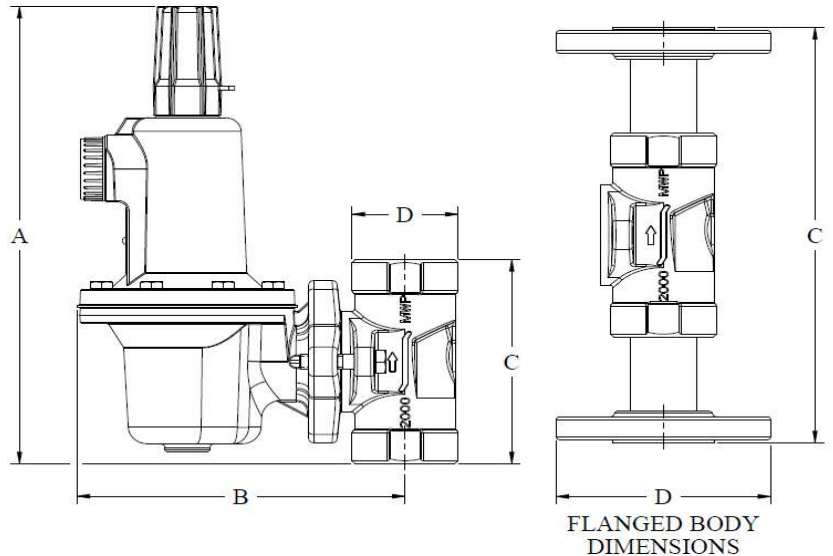

Table 1: Product Specifications	
Process Connections	
Threaded Connections	1" and 2" NPT
Flanged Connections	1" and 2" 150, 300, and 600 LB.
Outlet Pressure (Spring) Ranges	5-20 psi (Yellow) 15-40 psi (Green) 35-80 psi (Blue) 10-95 psi (Black) 70-150 psi (Red)
Orifice Sizes	1/8", 3/16", 1/4", 3/8", 1/2"
Materials of Construction	
Orifice Seal	Nitrile, Nylon, Fluorocarbon
Diaphragm & O-Rings	Nitrile, Fluorocarbon
Body	ASTM A216 WCC Carbon Steel
Flanges	ASTM A105 Carbon Steel
Diaphragm & Spring Housing	A380 Die Cast Aluminum
Orifice & Seal Holder	316 Stainless Steel

Table 2: Dimensional Information				
Model	A	B	C	D
1" NPT	10-1/16"	6-1/2"	4-15/32"	2-1/8"
1" 150 LB. Flange	12-3/8"	6-1/2"	9-1/8"	4-1/4"
1" 300 LB. Flange	12-3/8"	6-1/2"	9-1/8"	4-7/8"
1" 600 LB. Flange	12-3/8"	6-1/2"	9-1/8"	4-7/8"
2" NPT	10-11/32"	6-31/32"	5-1/16"	3-1/4"
2" 150 LB. Flange	13-1/2"	6-31/32"	11-3/8"	6"
2" 300 LB. Flange	13-1/2"	6-31/32"	11-3/8"	6-1/2"
2" 600 LB. Flange	13-1/2"	6-31/32"	11-3/8"	6-1/2"

Table 3: Operating Parameters	
Maximum Inlet Pressure	See Table 4
Body Pressure Rating	2000 psi
150 LB. Flange Rating	285 psi at 100° F.
300 LB. Flange Rating	740 psi at 100° F.
600 LB. Flange Rating	1480 psi at 100° F.
Maximum Outlet Pressure	Determined by Spring Selection
Maximum Diaphragm Housing Overpressure to Prevent Damage to Internal Components	60 psi Above Set Point
Maximum Diaphragm Housing Pressure to Prevent Leakage to the Atmosphere	250 psi
Maximum Diaphragm Housing Pressure to Prevent Burst	375 psi
Temperature Range	-20° - 180° F. (0 - 180° F. FKM Only)

Table 4: Maximum Inlet Pressures, psi				
Outlet Pressure (Spring) Range	Orifice Size	Nitrile Orifice Seal	Nylon Orifice Seal	FKM Orifice Seal
5-20 psi* (Yellow)	1/8"	1000	1000	300
	3/16"	750	750	300
	1/4"	500	500	300
	3/8"	300	300	300
	1/2"	250	250	250
15-40 psi (Green)	1/8"	1000	1500	300
	3/16"	1000	1000	300
	1/4"	750	750	300
	3/8"	500	500	300
	1/2"	300	300	300
35-80 psi (Blue)	1/8"	1000	2000	300
	3/16"	1000	1750	300
	1/4"	1000	1500	300
	3/8"	1000	1000	300
	1/2"	750	750	300
70-150 psi (Red)	1/8"	1000	2000	300
	3/16"	1000	2000	300
	1/4"	1000	1750	300
	3/8"	1000	1250	300
	1/2"	750	750	300
10-95 psi (Black)	When using the 10-95 psi (Black) spring, select the orifice size that falls within the application parameters described in this table.			
* For outlet pressure settings under 10 psi, the inlet pressure should not exceed 100 psi.				

Orifice Selection Instructions:

Select the correct orifice size by comparing the wide open flow capacity at the application conditions to the flow rate needed for the specific application. First, calculate the flow rate, Q, through each orifice size using the Universal Gas Sizing equation (Equation 1), the wide open flow coefficients, and the correct application conditions. Then select the smallest orifice size that will meet the required flow needs. After selecting the orifice, check to make sure that the application inlet pressure does not exceed the pressure rating listed in Table 4.

Variables:

- Q = Flow Rate, SCFH
- T = Gas Temperature @ Regulator Inlet, °Rankine
- G = Gas Specific Gravity
- P1 = Pressure @ Regulator Inlet, psia
- ΔP = Pressure Drop Across Regulator, psia
- Cg = Gas Sizing Coefficient
- Cv = Liquid Sizing Coefficient
- C1 = Flow Coefficient

Equation 1:

$$Q = \sqrt{\frac{520}{GT}} C_g P_1 \text{ SIN} \left[\left(\frac{3417}{C_1} \right) \sqrt{\frac{\Delta P}{P_1}} \right] \text{ DEG}$$

Equation 2:

$$Q = \sqrt{\frac{520}{GT}} C_g P_1$$

Note: When $[(3417/C_1) \cdot \sqrt{(\Delta P/P_1)}] \geq 90^\circ$ critical flow will occur. In all critical flow conditions, use equation 2.

Table 5: Wide Open Flow Coefficients				
	Orifice	Cg	Cv	C1
1" NPT & 1" Flanged Models	1/8"	16	0.51	30.6
	3/16"	33	1.03	32.0
	1/4"	54	1.88	28.7
	3/8"	112	3.24	34.6
	1/2"	193	6.27	30.8
2" NPT & 2" Flanged Models	1/8"	15	0.52	29.6
	3/16"	34	1.05	32.4
	1/4"	51	1.95	26.2
	3/8"	113	3.49	32.4
	1/2"	205	6.48	31.6
All flow coefficients were determined using lab tested data.				

Overpressure Protection:

the Model KPRL Pressure Regulator must always be used with overpressure protection. Use Equation 1 to size for the appropriate relief valve.

Installation Instructions:

1. The KPRL's body (2) can be rotated to accommodate different space requirements. Refer to the section titled, "Reorientation Instructions" for procedures.
2. Ensure that all pressure has been eliminated from the lines in which the regulator will be installed.
3. Inspect process piping and regulator inlet and outlet ports for any damage or debris. Contact factory if any regulator damage is present.
4. Pressure gauges and isolation valves should be installed at the inlet and outlet of each regulator.
5. A bleed valve should be installed at the outlet of each regulator to allow for proper depressurization.
6. Install the regulator with the body flow arrow pointing in the direction of flow. Kenco Engineering recommends using PTFE based thread sealant paste on all threaded connections.
7. Overpressure protection must be used in all KPRL applications. Refer to the section titled, "Overpressure Protection" for information on relief valve sizing.

Startup Instructions:

1. Prior to startup, the regulator must be fully isolated from all process pressure.
2. Slowly introduce the regulator to upstream pressure. At the factory, the KPRL is set at the lower end of the specified outlet range. Since inlet pressures are application specific, the startup outlet pressure may differ from the factory setting.
3. Slowly introduce the regulator to the downstream pressure. Watch the downstream pressure gauge while opening the downstream isolation valve and make sure the regulator is not over-pressurized.
4. Check all connections for leaks.
5. Adjust the regulator to the desired set point by turning the adjustment screw (13) clockwise to increase pressure and counterclockwise to decrease. Do not set the regulator at a pressure that exceeds the range noted on identification plate.
6. Tighten the lock nut (12) to set the pressure and cover the adjustment screw with the adjustment screw cap (14).

Shutdown Instructions:

1. Loosen the adjustment screw (13) until the spring (8) is no longer compressed.
2. Close the inlet and outlet isolation valves.
3. After the regulator has been fully isolated, bleed off all pressure from inside the regulator using the bleed valve located at the regulator's outlet.

General Maintenance Notes:

1. The KPRL must be properly shut down and isolated from all pressure prior to performing maintenance operations. See shutdown instructions for shutdown procedures.
2. All maintenance operations can be completed without removing the body (2) from the piping setup.
3. Upon reassembly, always ensure that the valve booster (21) is pointing in the direction of flow (see Figure 5).

Orifice Replacement Instructions:

1. Remove the body connection screws (1).
2. Remove the orifice (3) from the body (2).
3. Apply anti-seize lubricant to the threads of the new orifice and install in the body to 25 ft.-lbs.
4. Apply anti-seize lubricant to the threads of the body connection screws and reassemble as shown in Figures 3 and 5. Torque the screws to 10 ft.-lbs.

Spring Replacement Instructions:

1. Loosen the adjustment screw (13) until the spring (8) is no longer compressed.
2. Remove the spring housing (10), spring compression cup (9), and spring.
3. Place the new spring on top of the diaphragm assembly (7) and place the spring compression cup on top of the new spring.
4. Use the adjustment screw to hold the spring and spring compression cup in place while reassembling the regulator.
5. Upon reassembly, torque the spring housing screws (11) to 100 in.-lbs.
6. If the new spring is for a different outlet pressure range, mark the identification plate accordingly.

Orifice Seal Replacement Instructions:

1. Kenco Engineering recommends also replacing the other elastomers (5, 18, 22, 24, 25) when replacing the orifice seal. These items come standard in the repair kit.
2. Remove the body connection screws (1).
3. Remove the hitch pin (26) and orifice seal (20).
4. Install the new orifice seal and hitch pin.
5. Apply anti-seize lubricant to the body connections screws and torque to 10 ft.-lbs. upon reassembly.

Diaphragm Replacement Instructions:

1. Kenco Engineering recommends also replacing the other elastomers (5, 20, 22, 24, 25) when replacing the diaphragm. These items come standard in the repair kit.
2. Disassemble the regulator as shown in Figure 3.
3. Remove the cap screw (15), spring retainer cup (16), and diaphragm plate (17) from the diaphragm assembly (7).
4. Install the new diaphragm (18) and reassemble the diaphragm assembly as shown in Figure 7. The diaphragm bolt holes must be aligned with the diaphragm rod (19) as shown in Figure 6.
5. Torque the cap screw to 100 in.-lbs. when rebuilding the diaphragm assembly.
6. Reassemble the regulator as shown in Figures 3 and 5. Torque the spring housing screws (11) to 100 in.-lbs. and apply anti-seize to the body connection screws (1) and torque to 10 ft.-lbs.

O-Ring and Stabilizer Gasket Replacement Instructions:

1. Kenco Engineering recommends also replacing the other elastomers (18 & 20) when replacing the o-rings and stabilizer gasket. These items come standard in the repair kit.

O-Ring and Stabilizer Gasket Replacement (continued):

2. Disassemble the regulator as shown in Figure 3.
3. Remove the hitch pin (26) from the valve stem assembly (4) and disassemble as shown in Figure 4.
4. Install the new o-ring (25) then place one new back-up ring (24) on each side of the o-ring.
5. Apply o-ring lubricant to the o-rings and back-up rings and slide the valve stem guide (23) over the o-rings and back-up rings.
6. Reassemble the valve stem assembly as shown in Figure 4 with a new stabilizer gasket (22).
7. Reassemble the regulator as shown in Figures 3 and 5 with a new o-ring (5).
8. Upon reassembly, torque the spring housing screws (11) to 100 in.-lbs., apply anti-seize to the body connection screws (1), and torque the body connection screws to 10 ft.-lbs.

Reorientation Instructions:

1. The body (2) can be rotated 360 degrees from its original position and has four possible orientations.
2. Remove the body connection screws (1) and rotate the body and valve booster (21) to the desired orientation.
3. Apply anti-seize to the body connection screws and torque to 10 ft.-lbs during reassembly.
4. The spring housing vent (10) must be oriented to where water and debris cannot collect inside the spring housing and the spring housing can be rotated 360 degrees to accommodate.
5. To rotate the spring housing, loosen the adjustment screw (13) until the spring (8) is no longer compressed, remove the spring housing screws (11), spring, spring compression cup (9), and spring housing then reassemble the regulator with the spring housing in the desired position.
6. Use the adjustment screw to hold the spring and spring compression cup in place while reassembling the regulator.
7. Torque the spring housing screws to 100 in.-lbs.

Table 6: Parts List		
Item	Qty.	Description
1	2	Screw, Body Connection (Steel)
2	1	Body (Steel)
3	1	Orifice (316 Stainless Steel)
4	1	Stem, Valve (Assembly)
5	1	O-Ring, 2-221 (O-Ring Matl.)
6	1	Housing, Diaphragm (Assembly)
7	1	Diaphragm (Assembly)
8	1	Spring (Steel)
9	1	Cup, Spring Compression (Steel)
10	1	Housing, Spring (Assembly)
11	8	Screw, Spring Housing (Steel)
12	1	Nut, Lock (Steel)
13	1	Screw, Adjustment (Steel)
14	1	Cap, Adjustment Screw (Plastic)
15	1	Cap Screw (Steel)
16	1	Cup, Spring Retainer (Steel)
17	1	Plate, Diaphragm (Steel)
18	1	Diaphragm (Diaphragm Matl.)
19	1	Rod, Diaphragm (Aluminum)
20	1	Seal, Orifice (316 S.S. & Seal Matl.)
21	1	Booster, Valve (Nylon)
22	1	Gasket, Stabilizer (O-Ring Matl.)
23	1	Guide, Valve Stem (316 S.S.)
24	2	Ring, Back-UP (PTFE)
25	1	O-Ring, 2-010 (O-Ring Matl.)
26	1	Pin, Hitch (302 Stainless Steel)
27	1	Stem, Valve (316 Stainless Steel)

Table 7: Repair Kit Part Numbers

Part Number	Contains
KPRL-B-B-RK	Nitrile Elastomers (5, 18, 20, 22, 25), PTFE Back-up Rings (24), Stainless Steel Hitch Pin (26)
KPRL-N-B-RK	Nylon Seal (20), Nitrile Elastomers (5, 18, 22, 25), PTFE Back-up Rings (24), S.S. Hitch Pin (26)
KPRL-V-V-RK	FKM Elastomers (5, 18, 20, 22, 25), PTFE Back-up Rings (24), S.S. Hitch Pin (26)
KPRL-N-V-RK	Nylon Seal (20), FKM Elastomers (5, 18, 22, 25), PTFE Back-up Rings (24), S.S. Hitch Pin (26)
KPRL-ORIFICE-125-RK	1/8" Orifice
KPRL-ORIFICE-188-RK	3/16" Orifice
KPRL-ORIFICE-250-RK	1/4" Orifice
KPRL-ORIFICE-375-RK	3/8" Orifice
KPRL-ORIFICE-500-RK	1/2" Orifice
KPRL-SPRING-20-RK	5-20 psi Spring (Yellow)
KPRL-SPRING-40-RK	15-40 psi Spring (Green)
KPRL-SPRING-80-RK	35-80 psi Spring (Blue)
KPRL-SPRING-95-RK	10-95 psi Spring (Black)
KPRL-SPRING-15-RK	70-150 psi Spring (Red)

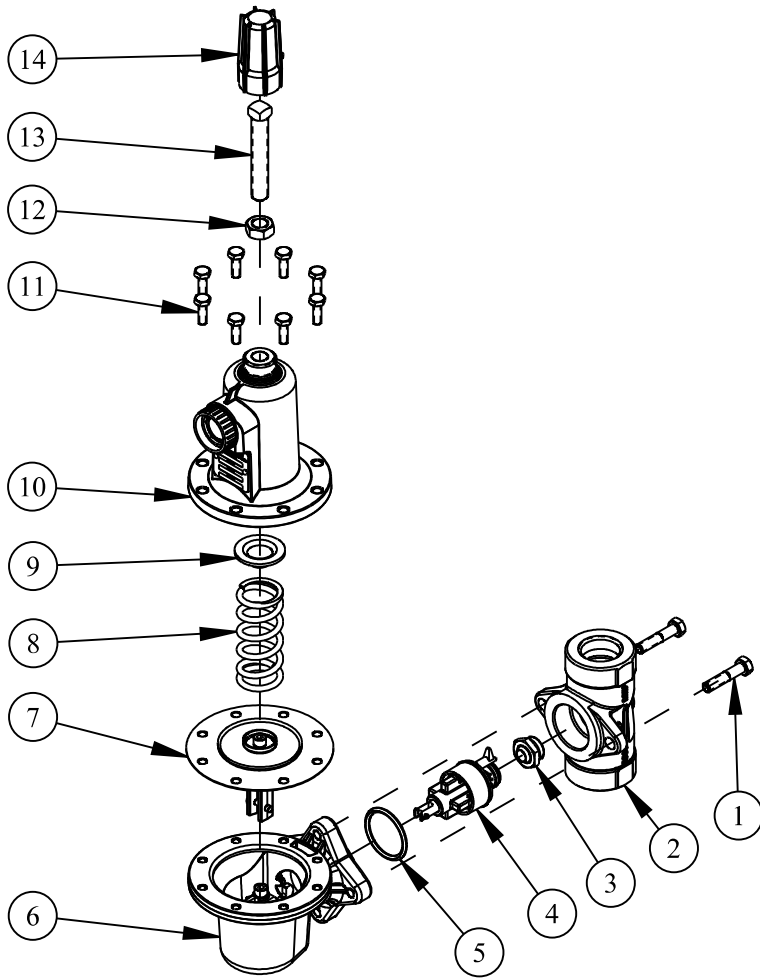

FIGURE 3: KPRL DISASSEMBLED

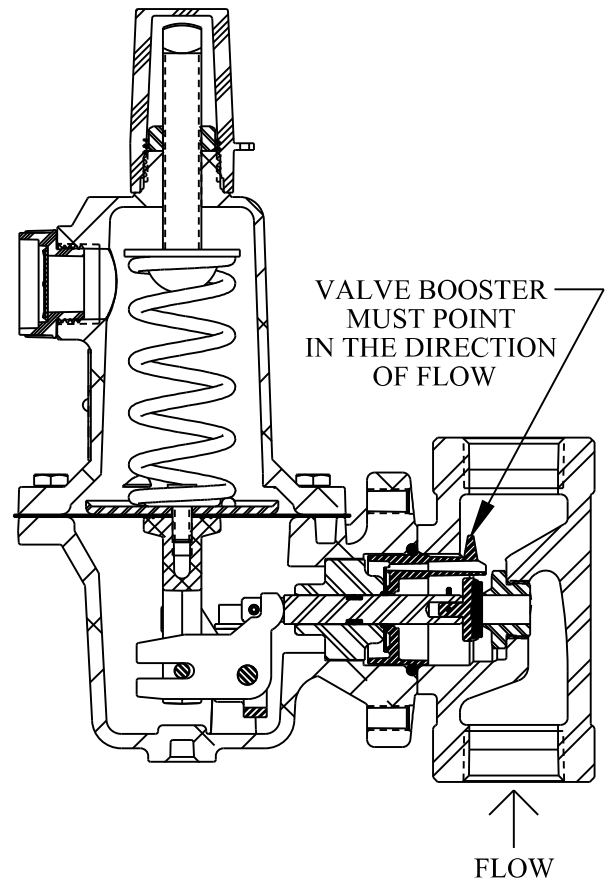

FIGURE 5: KPRL CROSS-SECTION

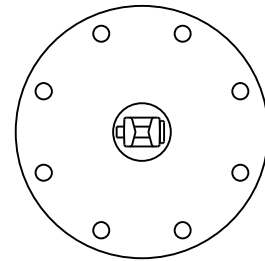

FIGURE 6: DIAPHRAGM ASSEMBLY
(BOTTOM VIEW)

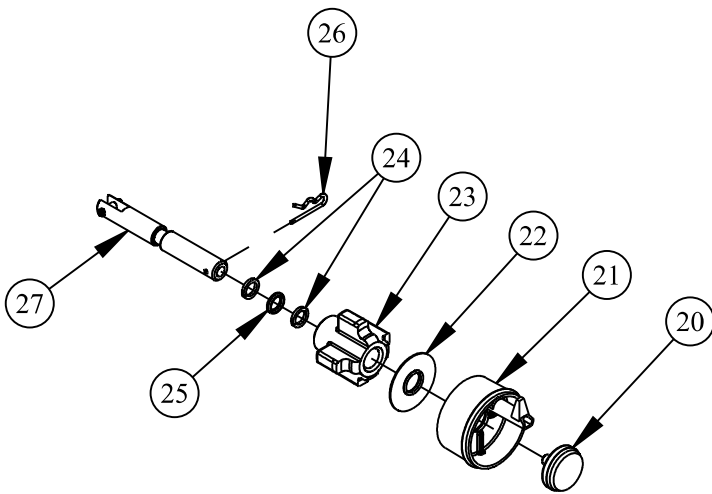

FIGURE 4: VALVE STEM ASSEMBLY

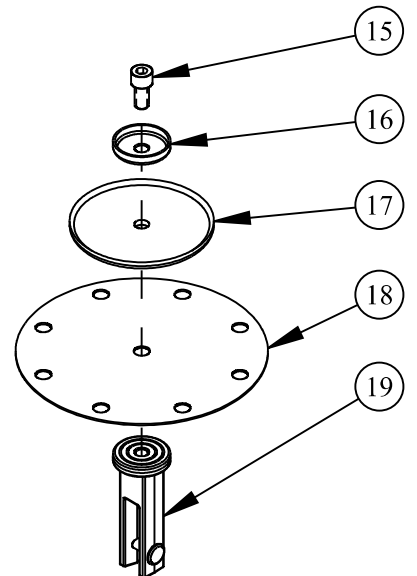

FIGURE 7: DIAPHRAGM ASSEMBLY