

## KENCO 16, 30 AND 55 GALLON TANK ILLUSTRATIONS

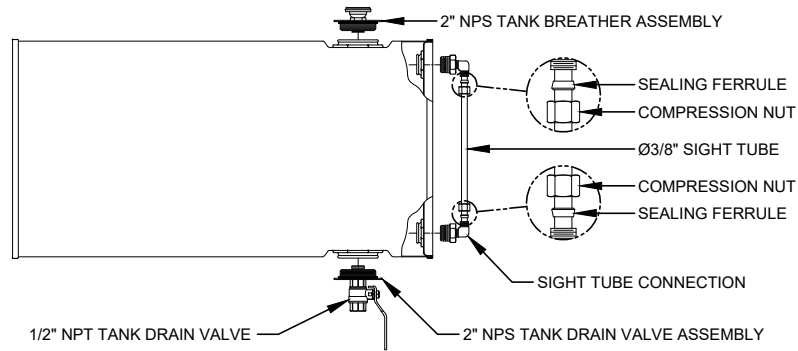

**MODEL K16G, K30G & K55G**

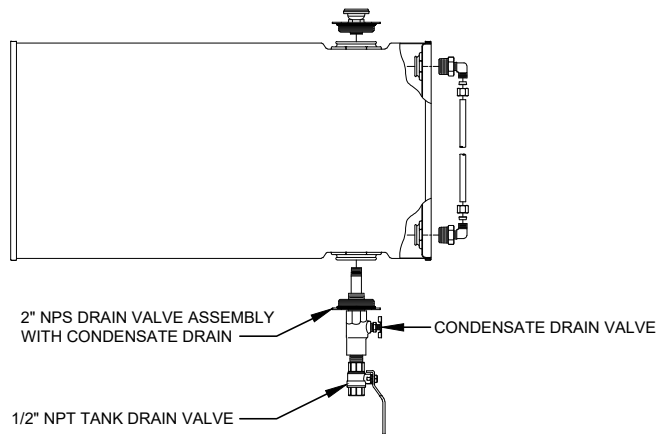

**MODEL K16G-CD, K30G-CD & K55G-CD**

## KENCO 16, 30 AND 55 GALLON TANK ASSEMBLY INSTRUCTIONS

1. KENCO TANKS SHIP WITH A TANK KIT CONTAINING ALL THE PARTS NECESSARY TO ASSEMBLE THE MODEL OPTION ORDERED. SEE ILLUSTRATIONS ON LEFT-HAND SIDE OF SHEET FOR VARIOUS MODEL CONFIGURATIONS.
2. MAKE SURE TANK IS THE SIZE ORDERED.
3. MAKE SURE TANK KIT CONTAINS THE PARTS REQUIRED TO BUILD THE TANK MODEL OPTION REQUESTED. (EXAMPLES: K16G-TK AND K16G-CD-TK).
4. REMOVE THE EXISTING TANK PORT THREADED PLUGS.
5. INSTALL 2" NPS TANK DRAIN VALVE ASSEMBLY.  
NOTE: 2" NPS DRUM PLUG IS EQUIPPED WITH A SEAL THAT DOES NOT REQUIRE AN EXCESSIVE AMOUNT OF TORQUE TO ACHIEVE A POSITIVE SEAL. DO NOT OVER TIGHTEN.
6. PREPARE TANK KIT PARTS HAVING NPT MALE PIPE THREADS FOR INSTALLATION BY WRAPPING THEM WITH PTFE TAPE SUPPLIED WITH TANK KIT.
7. INSTALL SIGHT TUBE CONNECTIONS INTO TANK WITH SIGHT TUBE PORTS FACING EACH OTHER AS SHOWN IN ILLUSTRATIONS.
8. REMOVE COMPRESSION NUT AND SEALING FERRULE FROM UPPER AND LOWER SIGHT TUBE CONNECTIONS.
9. PREPARE TO INSTALL Ø3/8" SIGHT TUBE.
10. INSTALL Ø3/8" SIGHT TUBE WITHOUT COMPRESSION NUTS OR SEALING FERRULES INTO UPPER OR LOWER SIGHT TUBE CONNECTION AND BEND AS REQUIRED TO INSTALL INTO CONNECTION ON OPPOSITE END.  
NOTE: Ø3/8" SIGHT TUBE SHOULD HAVE 1/16" TO 1/8" OF PLAY AFTER INSTALLATION.
11. AFTER FINAL CONFIRMATION THAT Ø3/8" SIGHT TUBE LENGTH IS CORRECT, REMOVE SIGHT TUBE AND SLIDE COMPRESSION NUTS AND SEALING FERRULES OVER EACH END OF THE SIGHT TUBE AS SHOWN.  
NOTE: IT IS IMPORTANT THAT THE SMALL END OF THE SEALING FERRULES BE ORIENTED AS SHOWN IN ILLUSTRATIONS.
12. REINSTALL Ø3/8" SIGHT TUBE AND TIGHTEN COMPRESSION NUTS 1/4 TO 1/2 TURN BEYOND HAND TIGHT TO ACHIEVE A POSITIVE SEAL.
13. MOUNT TANK IN A HORIZONTAL POSITION WITH 1/2" NPT TANK DRAIN VALVE ON BOTTOM AS REQUIRED FOR YOUR APPLICATION.
14. MAKE SURE 1/2" NPT TANK DRAIN VALVE AND CONDENSATE DRAIN VALVE ARE IN THE CLOSED POSITION.
15. FILL TANK WITH OIL FOR YOUR SERVICE THROUGH 2" NPS PORT ON TOP OF TANK AND CHECK FOR LEAKS.
16. TIGHTEN UP ANY CONNECTIONS THAT EXHIBIT ANY SIGN OF A LEAK.
17. INSTALL 2" NPS TANK BREATHER ASSEMBLY ON TOP OF TANK.  
NOTE: 2" NPS DRUM PLUG IS EQUIPPED WITH A SEAL THAT DOES NOT REQUIRE AN EXCESSIVE AMOUNT OF TORQUE TO ACHIEVE A POSITIVE SEAL. DO NOT OVER TIGHTEN.
18. INSTALL 1/2" NPT TANK DRAIN VALVE PIPING AS REQUIRED FOR YOUR APPLICATION.
19. OPEN 1/2" NPT TANK DRAIN VALVE TO CHECK PIPING FOR LEAKS AND TO PUT TANK INTO SERVICE.

## SIGHT TUBE REPLACEMENT INSTRUCTIONS

1. MAKE SURE YOU HAVE THE CORRECT SIGHT TUBE REPAIR KIT (EXAMPLES: K16G-RK AND K16G-CD-RK).
2. MAKE SURE OIL LEVEL IN TANK IS BELOW THE VISUAL INDICATION IN Ø3/8" SIGHT TUBE.
3. COMPLETELY LOOSEN Ø3/8" SIGHT TUBE COMPRESSION NUTS.
4. CAREFULLY REMOVE EXISTING Ø3/8" SIGHT TUBE, COMPRESSION NUTS AND SEALING FERRULES.
5. REPLACE EXISTING Ø3/8" SIGHT TUBE AND SEALING FERRULES WITH NEW ONES SUPPLIED.
6. FOLLOW STEPS 9 THROUGH 12 ABOVE FOR PROPER INSTALLATION.
7. FILL TANK AND CHECK Ø3/8" SIGHT TUBE CONNECTIONS FOR LEAKS.
8. TIGHTEN COMPRESSION NUTS SLIGHTLY TO STOP LEAK IF REQUIRED.



P.O. Box 470426 --- Tulsa, Oklahoma 74147  
Phone: 918-663-4406 --- Fax.: 918-663-4480  
www.kenco-eng.com --- E-mail: info@kenco-eng.com

62911 (1 OF 2)  
(REV. A)  
[05-24-11]

**KENCO 16, 30 AND 55 GALLON FIRE SAFE TANKS  
(ILLUSTRATIONS)**

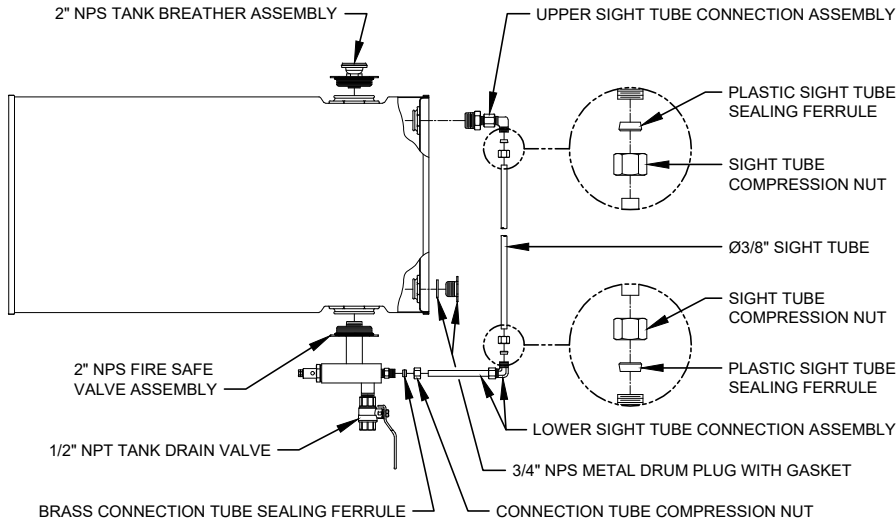

**MODEL K16G-FS, K30G-FS & K55G-FS**

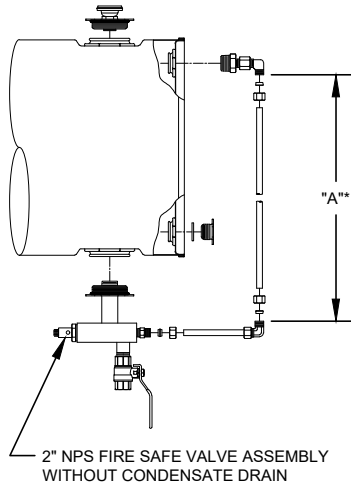

**K16G-FS, K30G-FS  
& K55G-FS**

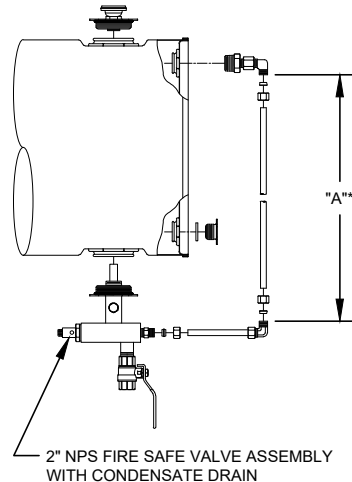

**K16G-FS-CD, K30G-FS-CD  
& K55G-FS-CD**

\*SIGHT TUBE LENGTH = "A" + 1/2". MAKE SURE SIGHT TUBE IS CUT SQUARE AND IS FREE OF ANY BURRS. A PROPERLY CUT SIGHT TUBE SHOULD HAVE 1/16" TO 1/8" OF PLAY AFTER INSTALLATION.

**KENCO 16, 30 AND 55 GALLON FIRE SAFE TANKS  
(ASSEMBLY ILLUSTRATIONS)**

1. KENCO TANKS SHIP WITH A TANK KIT CONTAINING ALL THE PARTS NECESSARY TO ASSEMBLE THE MODEL OPTION ORDERED. SEE ILLUSTRATIONS ON LEFT-HAND SIDE OF SHEET FOR VARIOUS MODEL CONFIGURATIONS.
2. MAKE SURE TANK IS THE SIZE ORDERED.
3. MAKE SURE TANK KIT CONTAINS THE PARTS REQUIRED TO BUILD THE TANK MODEL OPTION REQUESTED. (EXAMPLES: K16G-FS-TK AND K16G-FS-CD-TK).
4. REMOVE THE EXISTING TANK PORT THREADED PLUGS.
5. INSTALL 3/4" NPS METAL DRUM PLUG WITH GASKET INTO THE LOWER PORT ON FRONT FACE OF TANK.  
NOTE: DRUM PLUG IS EQUIPPED WITH A GASKET THAT DOES NOT REQUIRE AN EXCESSIVE AMOUNT OF TORQUE TO ACHIEVE A POSITIVE SEAL.
6. INSTALL 2" NPS FIRE SAFE VALVE ASSEMBLY AND ORIENT AS SHOWN IN ILLUSTRATIONS.  
NOTE: 2" NPS DRUM PLUG IS EQUIPPED WITH A SEAL THAT DOES NOT REQUIRE AN EXCESSIVE AMOUNT OF TORQUE TO ACHIEVE A POSITIVE SEAL. DO NOT OVER TIGHTEN.
7. PREPARE 3/4" NPT PIPE THREADS ON UPPER SIGHT TUBE CONNECTION ASSEMBLY FOR INSTALLATION BY WRAPPING WITH PTFE TAPE SUPPLIED WITH TANK KIT.
8. INSTALL UPPER SIGHT TUBE CONNECTION ASSEMBLY INTO THE UPPER PORT ON FRONT FACE OF TANK SO THAT 90° ELBOW IS POINTING STRAIGHT DOWN TOWARDS 2" NPS FIRE SAFE VALVE ASSEMBLY ON BOTTOM OF TANK.
9. REMOVE CONNECTION TUBE COMPRESSION NUT AND BRASS CONNECTION TUBE SEALING FERRULE FROM TUBE FITTING ON FRONT FACE OF 2" NPS FIRE SAFE VALVE ASSEMBLY BODY.
10. PICK UP LOWER SIGHT TUBE CONNECTION ASSEMBLY AND SLIDE CONNECTION TUBE COMPRESSION NUT AND BRASS CONNECTION TUBE SEALING FERRULE ONTO Ø3/8" CONNECTION TUBE AS SHOWN.
11. INSERT Ø3/8" TUBE ON LOWER SIGHT TUBE CONNECTION ASSEMBLY INTO TUBE FITTING ON FRONT FACE OF 2" NPS FIRE SAFE VALVE ASSEMBLY BODY AND LOOSELY TIGHTEN COMPRESSION NUT AGAINST BRASS FERRULE.
12. REMOVE SIGHT TUBE COMPRESSION NUT AND PLASTIC SIGHT TUBE SEALING FERRULE FROM LOWER AND UPPER SIGHT TUBE CONNECTION ASSEMBLY.
13. PREPARE TO INSTALL Ø3/8" SIGHT TUBE.  
NOTE: DUE TO 3/4" NPT PIPE THREAD ENGAGEMENT VARIATIONS ON 2" NPS FIRE SAFE VALVE ASSEMBLY, THE Ø3/8" SIGHT TUBE SUPPLIED WILL HAVE TO BE CUT TO THE PROPER LENGTH USING A TUBING CUTTER OR SAW. SEE ILLUSTRATION FOR SIGHT TUBE CUTTING LENGTH FORMULA AND CUT SIGHT TUBE TO LENGTH.
14. INSTALL Ø3/8" SIGHT TUBE WITHOUT SIGHT TUBE COMPRESSION NUTS OR PLASTIC SIGHT TUBE SEALING FERRULES INTO UPPER OR LOWER SIGHT TUBE CONNECTION PORT AND BEND Ø3/8" SIGHT TUBE AS REQUIRED TO INSTALL INTO SIGHT TUBE CONNECTION PORT ON OPPOSITE END.  
NOTE: Ø3/8" SIGHT TUBE SHOULD HAVE 1/16" TO 1/8" OF PLAY AFTER INSTALLATION.
15. AFTER FINAL CONFIRMATION THAT Ø3/8" SIGHT TUBE LENGTH IS CORRECT, REMOVE SIGHT TUBE AND SLIDE SIGHT TUBE COMPRESSION NUTS AND PLASTIC SIGHT TUBE SEALING FERRULES OVER EACH END OF THE SIGHT TUBE AS SHOWN.  
NOTE: IT IS IMPORTANT THAT SMALL END OF PLASTIC SIGHT TUBE SEALING FERRULE IS ORIENTED TOWARDS SIGHT TUBE PORT ON SIGHT TUBE CONNECTION ASSEMBLIES AS SHOWN IN ILLUSTRATIONS.
16. REINSTALL Ø3/8" SIGHT TUBE INTO UPPER AND LOWER SIGHT TUBE CONNECTION PORTS AND TIGHTEN SIGHT TUBE COMPRESSION NUTS 1/4 TO 1/2 TURN BEYOND HAND TIGHT TO ACHIEVE A POSITIVE SEAL.
17. WHILE ENSURING THAT Ø3/8" SIGHT TUBE IS PARALLEL WITH FRONT FACE OF TANK, BEGIN TIGHTENING CONNECTION TUBE COMPRESSION NUT ON FRONT FACE OF 2" NPS FIRE SAFE VALVE ASSEMBLY BODY.  
IMPORTANT: PLACE A WRENCH ON TUBE FITTING INSTALLED IN FRONT FACE OF 2" NPS FIRE SAFE VALVE ASSEMBLY BODY AND TIGHTEN COMPRESSION NUT AS REQUIRED TO ACHIEVE A POSITIVE SEAL.
18. MOUNT TANK IN A HORIZONTAL POSITION WITH 1/2" NPT TANK DRAIN VALVE ON BOTTOM AS REQUIRED FOR YOUR APPLICATION.  
NOTE: IT MAY BE NECESSARY TO INSTALL Ø3/8" SIGHT TUBE ONTO TANK AFTER MOUNTING TANK DEPENDING ON CLEARANCE ISSUES.
19. MAKE SURE 1/2" NPT TANK DRAIN VALVE IS IN THE CLOSED POSITION.
20. FILL TANK WITH OIL FOR YOUR SERVICE THROUGH 2" NPS PORT ON TOP OF TANK AND CHECK FOR LEAKS.
21. TIGHTEN CONNECTIONS THAT EXHIBIT ANY SIGN OF A LEAK.
22. INSTALL 2" NPS TANK BREATHER ASSEMBLY ON TOP OF TANK.  
NOTE: 2" NPS DRUM PLUG IS EQUIPPED WITH A SEAL THAT DOES NOT REQUIRE AN EXCESSIVE AMOUNT OF TORQUE TO ACHIEVE A POSITIVE SEAL. DO NOT OVER TIGHTEN.
23. INSTALL 1/2" NPT TANK DRAIN VALVE PIPING AS REQUIRED FOR YOUR APPLICATION.
24. OPEN 1/2" NPT TANK DRAIN VALVE TO CHECK PIPING FOR LEAKS AND TO PUT TANK INTO SERVICE.

**SIGHT TUBE REPLACEMENT INSTRUCTIONS**

1. MAKE SURE YOU HAVE THE CORRECT SIGHT TUBE REPAIR KIT (EXAMPLES: K16G-FS-RK AND K16G-FS-CD-RK).
2. MAKE SURE OIL LEVEL IN TANK IS BELOW THE VISUAL INDICATION IN Ø3/8" SIGHT TUBE.
3. COMPLETELY LOOSEN Ø3/8" SIGHT TUBE COMPRESSION NUTS.
4. CAREFULLY REMOVE EXISTING Ø3/8" SIGHT TUBE, SIGHT TUBE COMPRESSION NUTS AND PLASTIC SIGHT TUBE SEALING FERRULES.
5. REPLACE EXISTING Ø3/8" SIGHT TUBE AND PLASTIC SIGHT TUBE SEALING FERRULES WITH NEW ONES.
6. FOLLOW STEPS 13 THROUGH 16 ABOVE FOR PROPER INSTALLATION.
7. FILL TANK AND CHECK Ø3/8" SIGHT TUBE CONNECTIONS FOR LEAKS.
8. TIGHTEN COMPRESSION NUTS SLIGHTLY TO STOP LEAK IF REQUIRED.