

**KENCO 16, 30 AND 55 GALLON TANKS WITH 4400 SERIES LEVEL GAUGE
(ILLUSTRATIONS)**

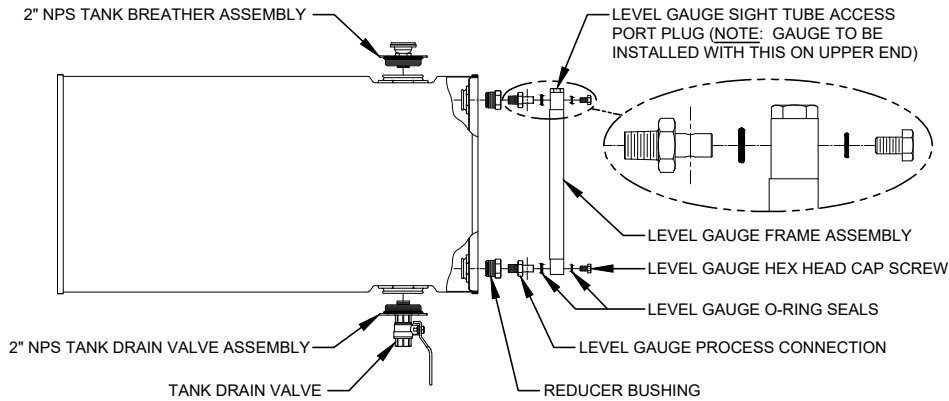

MODEL K16G-44, K30G-44 & K55G-44

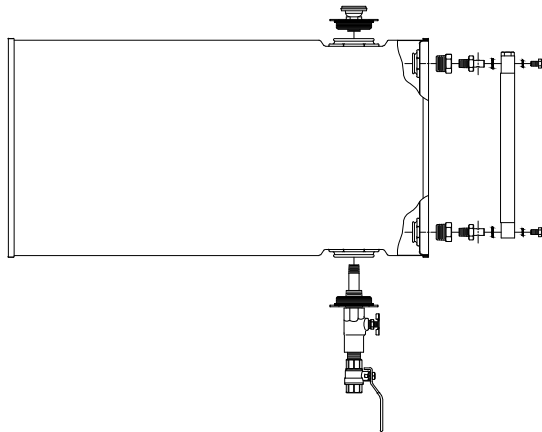

MODEL K16G-CD-44, K30G-CD-44 & K55G-CD-44

**KENCO 16, 30 AND 55 GALLON TANKS WITH 4400 SERIES LEVEL GAUGE
(ASSEMBLY INSTRUCTIONS)**

1. KENCO TANKS SHIP WITH A TANK KIT CONTAINING ALL THE PARTS NECESSARY TO ASSEMBLE THE MODEL OPTION ORDERED. SEE ILLUSTRATIONS ON LEFT-HAND SIDE OF SHEET FOR VARIOUS MODEL CONFIGURATIONS.
2. MAKE SURE TANK IS THE SIZE ORDERED.
3. MAKE SURE TANK KIT CONTAINS THE PARTS REQUIRED TO BUILD THE TANK MODEL OPTION REQUESTED. (EXAMPLES: K16G-44-TK AND K16G-CD-44-TK).
4. REMOVE THE EXISTING TANK PORT THREADED PLUGS.
5. INSTALL 2" NPS TANK DRAIN VALVE ASSEMBLY.
NOTE: 2" NPS DRUM PLUG IS EQUIPPED WITH A SEAL THAT DOES NOT REQUIRE AN EXCESSIVE AMOUNT OF TORQUE TO ACHIEVE A POSITIVE SEAL. DO NOT OVER TIGHTEN.
6. PREPARE TANK KIT PARTS HAVING NPT MALE PIPE THREADS FOR INSTALLATION BY WRAPPING THEM WITH PTFE TAPE SUPPLIED WITH TANK KIT.
7. INSTALL REDUCER BUSHINGS INTO FRONT FACE OF TANK AS SHOWN IN ILLUSTRATIONS.
8. THE 4400 SERIES LEVEL GAUGE IS SHIPPED COMPLETELY ASSEMBLED AND IT WILL BE NECESSARY TO REMOVE THE LEVEL GAUGE PROCESS CONNECTIONS BY UNSCREWING THE HEX HEAD CAP SCREWS AS SHOWN IN ILLUSTRATIONS.
9. INSTALL UPPER AND LOWER LEVEL GAUGE PROCESS CONNECTIONS TO TANK SO THAT CROSS-DRILLED HOLES ARE POINTING TOWARD EACH OTHER FROM TOP TO BOTTOM. CROSS-DRILLED HOLES ARE ILLUSTRATED BY VERTICAL CENTERLINES RUNNING THROUGH EACH CONNECTION.
NOTE: IT IS IMPORTANT THAT THE OUTSIDE HEXAGON FACES OF THE LEVEL GAUGE PROCESS CONNECTIONS BE FLUSH WITH EACH OTHER AFTER INSTALLATION SO THAT O-RING SEALS WILL SEAL PROPERLY AGAINST BACK OF UPPER AND LOWER GAUGE FRAME CONNECTION BLOCKS.
10. SLIDE LEVEL GAUGE O-RING SEAL ONTO CYLINDRICAL END OF EACH LEVEL GAUGE PROCESS CONNECTION.
11. SLIDE LEVEL GAUGE FRAME ASSEMBLY ONTO CYLINDRICAL END OF LEVEL GAUGE PROCESS CONNECTIONS WITH THE LEVEL GAUGE SIGHT TUBE ACCESS PORT PLUG LOCATED ON UPPER END AS SHOWN.
12. PREPARE TO REINSTALL LEVEL GAUGE HEX HEAD CAP SCREWS WITH O-RING SEALS INTO THE FRONT SIDE OF THE GAUGE FRAME CONNECTION BLOCKS. CAP SCREWS AND PROCESS CONNECTIONS ARE 300 SERIES STAINLESS STEEL AND THE USE OF ANTI-SEIZE LUBRICANT ON CAP SCREW THREADS IS RECOMMENDED TO PREVENT GALLING.
NOTE: LEVEL GAUGE O-RING SEALS DO NOT REQUIRE AN EXCESSIVE AMOUNT OF TORQUE TO ACHIEVE A POSITIVE SEAL. DO NOT OVER TIGHTEN LEVEL GAUGE HEX HEAD CAP SCREWS.
13. MOUNT TANK IN A HORIZONTAL POSITION WITH TANK DRAIN VALVE ON BOTTOM AS REQUIRED FOR YOUR APPLICATION.
14. MAKE SURE TANK DRAIN VALVE IS IN THE CLOSED POSITION.
15. FILL TANK WITH OIL FOR YOUR SERVICE THROUGH 2" NPS PORT ON TOP OF TANK AND CHECK FOR LEAKS.
16. TIGHTEN UP ANY CONNECTIONS THAT EXHIBIT ANY SIGN OF A LEAK.
17. INSTALL 2" NPS TANK BREATHER ASSEMBLY ON TOP OF TANK.
NOTE: 2" NPS DRUM PLUG IS EQUIPPED WITH A SEAL THAT DOES NOT REQUIRE AN EXCESSIVE AMOUNT OF TORQUE TO ACHIEVE A POSITIVE SEAL. DO NOT OVER TIGHTEN.
18. INSTALL TANK DRAIN VALVE PIPING AS REQUIRED FOR YOUR APPLICATION.
19. OPEN TANK DRAIN VALVE TO CHECK PIPING FOR LEAKS AND TO PUT TANK INTO SERVICE.

SIGHT TUBE REPLACEMENT INSTRUCTIONS

1. MAKE SURE YOU HAVE THE CORRECT SIGHT TUBE REPAIR KIT.
2. MAKE SURE OIL LEVEL IN TANK IS BELOW THE LOWER LEVEL GAUGE PROCESS CONNECTION.
3. REMOVE LEVEL GAUGE FRAME ASSEMBLY BY UNSCREWING THE LEVEL GAUGE HEX HEAD CAP SCREWS.
4. INSTALL REPLACEMENT SIGHT TUBE AND O-RING SEALS PER INSTRUCTIONS PROVIDED WITH REPAIR KIT.
5. FOLLOW STEPS 10 THROUGH 12 ABOVE FOR PROPER INSTALLATION.
6. FILL TANK AND CHECK LEVEL GAUGE FOR LEAKS.
7. TIGHTEN CONNECTIONS SLIGHTLY TO STOP LEAK IF REQUIRED.



P.O. Box 470426 --- Tulsa, Oklahoma 74147
Phone: 918-663-4406 --- Fax: 918-663-4480
www.kenco-eng.com --- E-mail: info@kenco-eng.com

62919 (1 OF 2)
(REV. A)
[05-25-11]

**KENCO 16, 30 AND 55 GALLON FIRE SAFE TANKS WITH -44 LEVEL GAUGE OPTION
(ILLUSTRATIONS)**

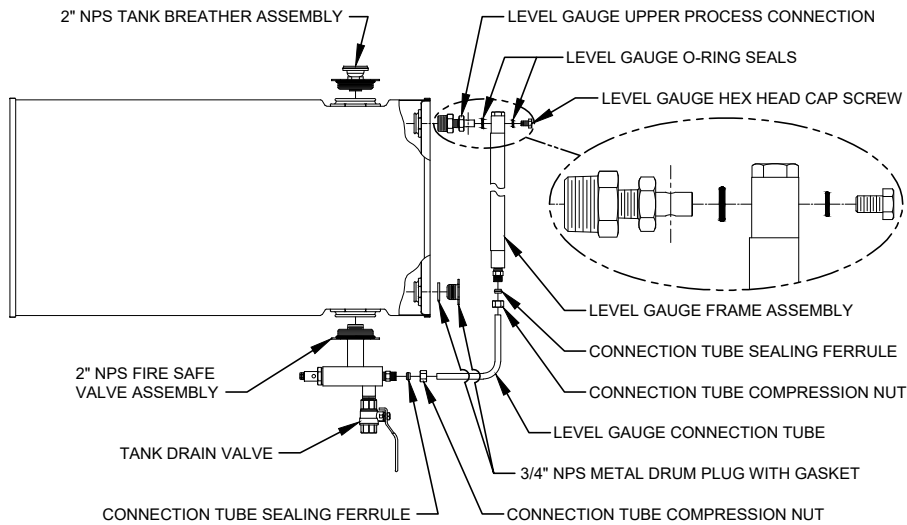

MODEL K16G-FS-44, K30G-FS-44 & K55G-FS-44

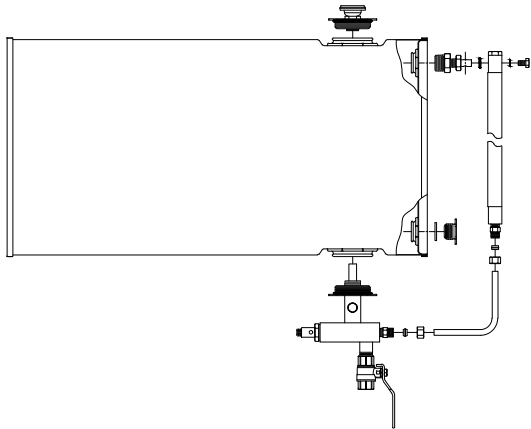

MODEL K16G-FS-CD-44, K30G-FS-CD-44 & K55G-FS-CD-44

**KENCO 16, 30 AND 55 GALLON FIRE SAFE TANKS WITH -44 LEVEL GAUGE OPTION
(ASSEMBLY INSTRUCTIONS)**

1. KENCO TANKS SHIP WITH A TANK KIT CONTAINING ALL THE PARTS NECESSARY TO ASSEMBLE THE MODEL OPTION ORDERED. SEE ILLUSTRATIONS ON LEFT-HAND SIDE OF SHEET FOR VARIOUS MODEL CONFIGURATIONS.
2. MAKE SURE TANK IS THE SIZE ORDERED.
3. MAKE SURE TANK KIT CONTAINS THE PARTS REQUIRED TO BUILD THE TANK MODEL OPTION REQUESTED. (EXAMPLES: K16G-FS-44-TK AND K16G-FS-CD-44-TK).
4. REMOVE THE EXISTING TANK PORT THREADED PLUGS.
5. INSTALL 3/4" NPS METAL DRUM PLUG WITH GASKET INTO THE LOWER PORT ON FRONT FACE OF TANK.
NOTE: DRUM PLUG IS EQUIPPED WITH A GASKET THAT DOES NOT REQUIRE AN EXCESSIVE AMOUNT OF TORQUE TO ACHIEVE A POSITIVE SEAL.
6. INSTALL 2" NPS FIRE SAFE VALVE ASSEMBLY AND ORIENT AS SHOWN IN ILLUSTRATIONS.
NOTE: 2" NPS DRUM PLUG IS EQUIPPED WITH A SEAL THAT DOES NOT REQUIRE AN EXCESSIVE AMOUNT OF TORQUE TO ACHIEVE A POSITIVE SEAL. DO NOT OVER TIGHTEN.
7. THE LEVEL GAUGE IS SHIPPED COMPLETELY ASSEMBLED AND IT WILL BE NECESSARY TO REMOVE THE UPPER PROCESS CONNECTION BY UNSCREWING THE HEX HEAD CAP SCREW AS SHOWN IN ILLUSTRATIONS.
8. PREPARE NPT MALE PIPE THREADS ON UPPER PROCESS CONNECTION FOR INSTALLATION BY WRAPPING WITH PTFE TAPE SUPPLIED WITH TANK KIT.
9. INSTALL UPPER PROCESS CONNECTION INTO THE UPPER PORT ON FRONT FACE OF TANK SO THAT CROSS-DRILLED HOLE IS POINTING TOWARD BOTTOM OF TANK.
NOTE: CROSS-DRILLED HOLE IS ILLUSTRATED BY VERTICAL CENTERLINE RUNNING THROUGH CONNECTION.
10. SLIDE LEVEL GAUGE O-RING SEAL ONTO CYLINDRICAL END OF LEVEL GAUGE UPPER PROCESS CONNECTION.
11. REMOVE COMPRESSION NUT AND SEALING FERRULE FROM LOWER END OF LEVEL GAUGE AND FRONT FACE OF FIRE SAFE VALVE ASSEMBLY.
12. PICK UP LEVEL GAUGE CONNECTION TUBE AND SLIDE COMPRESSION NUTS AND SEALING FERRULES ON EACH END AS SHOWN.
13. INSERT ONE END OF CONNECTION TUBE INTO COMPRESSION FITTING ON FRONT FACE OF FIRE SAFE VALVE ASSEMBLY AND LOOSELY TIGHTEN COMPRESSION NUT.
14. SLIDE COMPRESSION FITTING ON LOWER END OF LEVEL GAUGE OVER OTHER END OF CONNECTION TUBE AND LOOSELY TIGHTEN COMPRESSION NUT.
15. SLIDE LEVEL GAUGE FRAME ASSEMBLY ONTO CYLINDRICAL END OF LEVEL GAUGE UPPER PROCESS CONNECTION.
16. LINE UP LEVEL GAUGE WITH COMPRESSION FITTING ON FRONT FACE OF FIRE SAFE VALVE ASSEMBLY.
17. PREPARE TO REINSTALL LEVEL GAUGE HEX HEAD CAP SCREW INTO THE FRONT SIDE OF THE GAUGE FRAME UPPER CONNECTION BLOCK. CAP SCREW AND PROCESS CONNECTION ARE 300 SERIES STAINLESS STEEL AND THE USE OF ANTI-SEIZE LUBRICANT ON CAP SCREW THREADS IS RECOMMENDED TO PREVENT GALLING.
NOTE: LEVEL GAUGE O-RING SEALS DO NOT REQUIRE AN EXCESSIVE AMOUNT OF TORQUE TO ACHIEVE A POSITIVE SEAL. DO NOT OVER TIGHTEN LEVEL GAUGE HEX HEAD CAP SCREW.
18. MAKE SURE LEVEL GAUGE FRAME ASSEMBLY IS PARALLEL WITH FACE OF TANK AND BEGIN TIGHTENING COMPRESSION NUTS (FIRE SAFE VALVE COMPRESSION NUT FIRST) TO ACHIEVE A POSITIVE SEAL.
IMPORTANT: PLACE A WRENCH ON LOWER CONNECTION BLOCK OF LEVEL GAUGE WHEN TIGHTENING GAUGE COMPRESSION NUT TO AVOID BENDING FRAME AND POSSIBLE DAMAGE TO GLASS SIGHT TUBE.
19. MOUNT TANK IN A HORIZONTAL POSITION WITH TANK DRAIN VALVE ON BOTTOM AS REQUIRED FOR YOUR APPLICATION.
NOTE: IT MAY BE NECESSARY TO INSTALL LEVEL GAUGE ONTO TANK AFTER MOUNTING TANK DEPENDING ON CLEARANCE ISSUES.
20. MAKE SURE TANK DRAIN VALVE IS IN THE CLOSED POSITION.
21. FILL TANK WITH OIL FOR YOUR SERVICE THROUGH 2" NPS PORT ON TOP OF TANK AND CHECK FOR LEAKS.
22. TIGHTEN UP ANY CONNECTIONS THAT EXHIBIT ANY SIGN OF A LEAK.
23. INSTALL 2" NPS TANK BREATHER ASSEMBLY ON TOP OF TANK.
NOTE: 2" NPS DRUM PLUG IS EQUIPPED WITH A SEAL THAT DOES NOT REQUIRE AN EXCESSIVE AMOUNT OF TORQUE TO ACHIEVE A POSITIVE SEAL. DO NOT OVER TIGHTEN.
24. INSTALL TANK DRAIN VALVE PIPING AS REQUIRED FOR YOUR APPLICATION.
25. OPEN TANK DRAIN VALVE TO CHECK PIPING FOR LEAKS AND TO PUT TANK INTO SERVICE.

SIGHT TUBE REPLACEMENT INSTRUCTIONS

1. MAKE SURE YOU HAVE THE CORRECT SIGHT TUBE REPAIR KIT.
2. MAKE SURE OIL IS DRAINED FROM TANK.
3. REMOVE LEVEL GAUGE FRAME ASSEMBLY BY UNSCREWING THE LEVEL GAUGE HEX HEAD CAP SCREW AND COMPRESSION NUT LOCATED ON FRONT FACE OF FIRE SAFE VALVE.
4. INSTALL REPLACEMENT SIGHT TUBE AND O-RING SEALS PER INSTRUCTIONS PROVIDED WITH REPAIR KIT.
5. REINSTALL LEVEL GAUGE.
6. FILL TANK AND CHECK LEVEL GAUGE FOR LEAKS.
7. TIGHTEN CONNECTIONS SLIGHTLY TO STOP LEAK IF REQUIRED.