

FIRE SAFE VALVE
MODEL 50-FS:
 A=1/2"
 B=5/8"
 C=1-1/4"
 D=1-9/16"
 E=3-1/8"
 F=3-7/8"

MODEL KLCP-14-FS

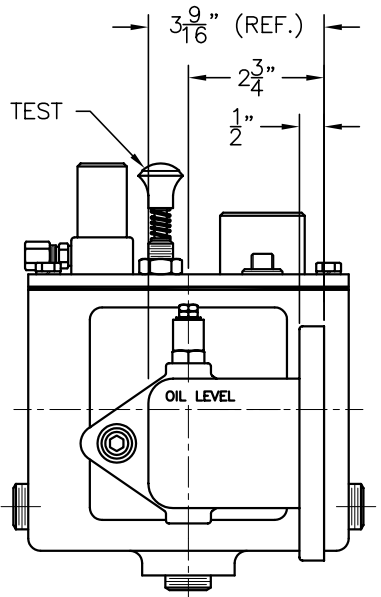
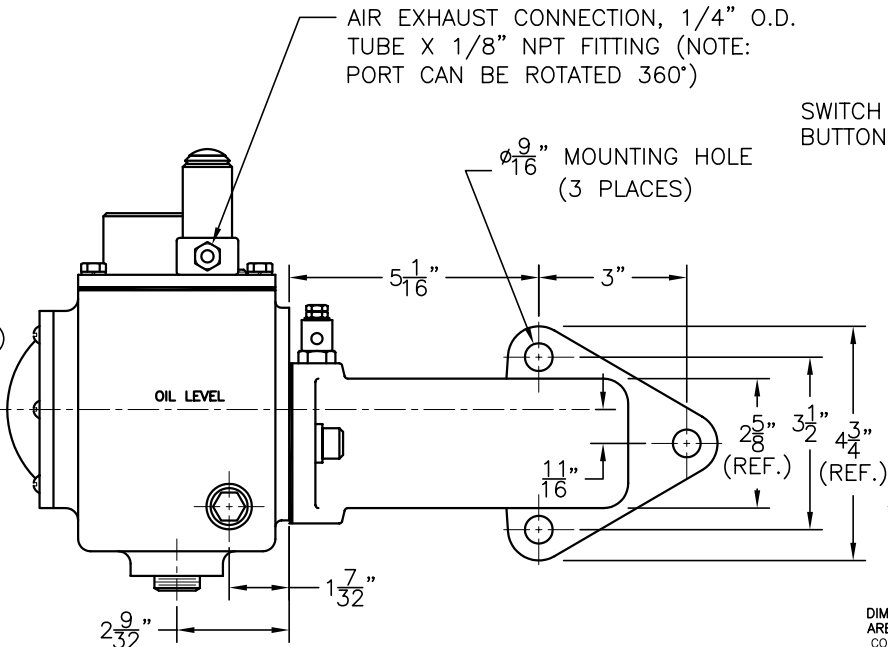

DIMENSIONS ARE FOR REFERENCE PURPOSES ONLY AND ARE SUBJECT TO CHANGE AT ANY TIME WITHOUT NOTICE. COPYRIGHT © 2004 KENCO INTERNATIONAL, INC. ALL RIGHTS RESERVED.

REV.	DATE	BY	ECN	EXPLANATION:
A	02-20-04	DS	-	CL OF MTG. ADAPTER WAS 1/4" BELOW OIL LEVEL; 3/8" PIPE PLUG WAS SHOWN AS A VENT PLUG; MTG. ADAPTER WAS SHOWN BACKWARDS IN BACK VIEW; UP-DATED MISC. REF. DIMS. ON CONTROLLER HOUSING

KENCO ENGINEERING COMPANY
 TULSA, OKLAHOMA
CONTROLLER, OIL LEVEL WITH MOUNT
(OUTLINE DRAWING) MODEL KLCP-14-FS
 DATE: 02-03-03 SHEET: 1 OF 1 DRAWING NUMBER
 DRN. BY: DS CHKD. BY: C-44781
 SCALE: NONE REVISION: A