

# MODEL KLCP-9

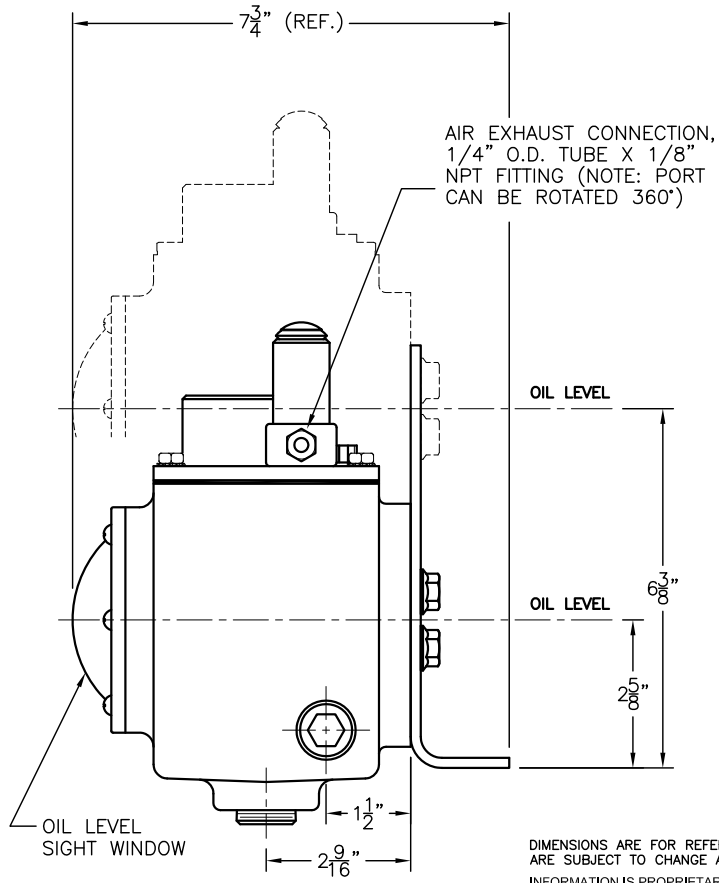
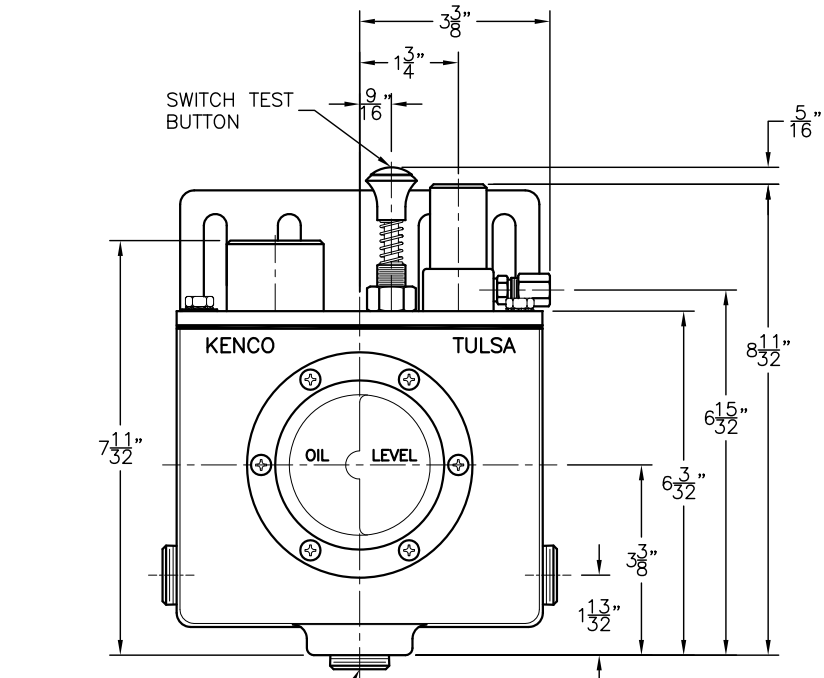
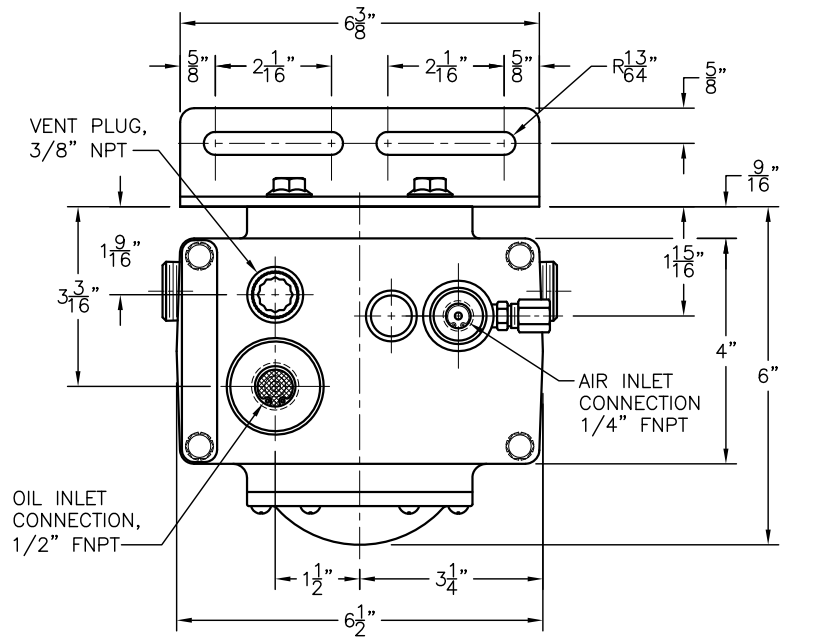

DIMENSIONS ARE FOR REFERENCE PURPOSES ONLY AND ARE SUBJECT TO CHANGE AT ANY TIME WITHOUT NOTICE. INFORMATION IS PROPRIETARY TO KENCO ENGINEERING CO.

## UNIVERSAL MOUNT BRACKET

REV.	DATE	BY	CHKD.	ECN	EXPLANATION:	KENCO ENGINEERING COMPANY TULSA, OKLAHOMA
A	12-08-11	DS	PAS	N/A	UPDATED TO REFLECT CASTING CHANGES	
						CONTROLLER, OIL LEVEL WITH MOUNT (OUTLINE DRAWING) MODEL KLCP-9
						DATE: 02-03-03 SHEET: 1 OF 1 DRAWING NUMBER
						DRN. BY: DS CHKD. BY: A C-44772
						SCALE: NONE REVISION: A