

MODEL KLCM-17

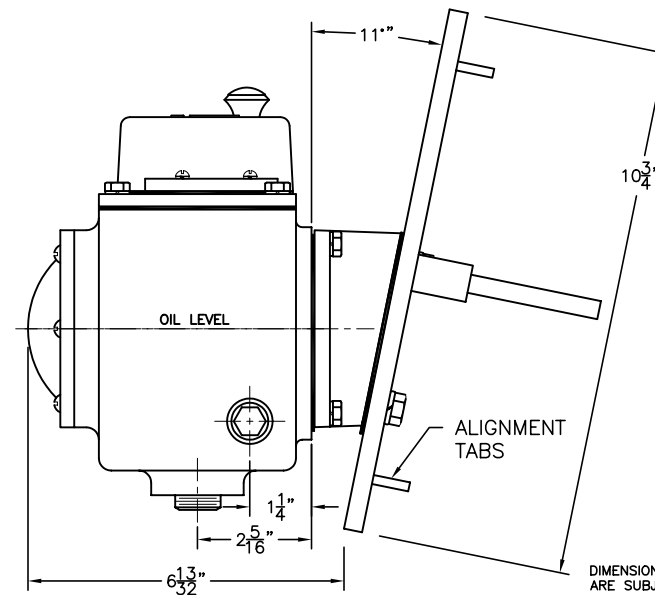
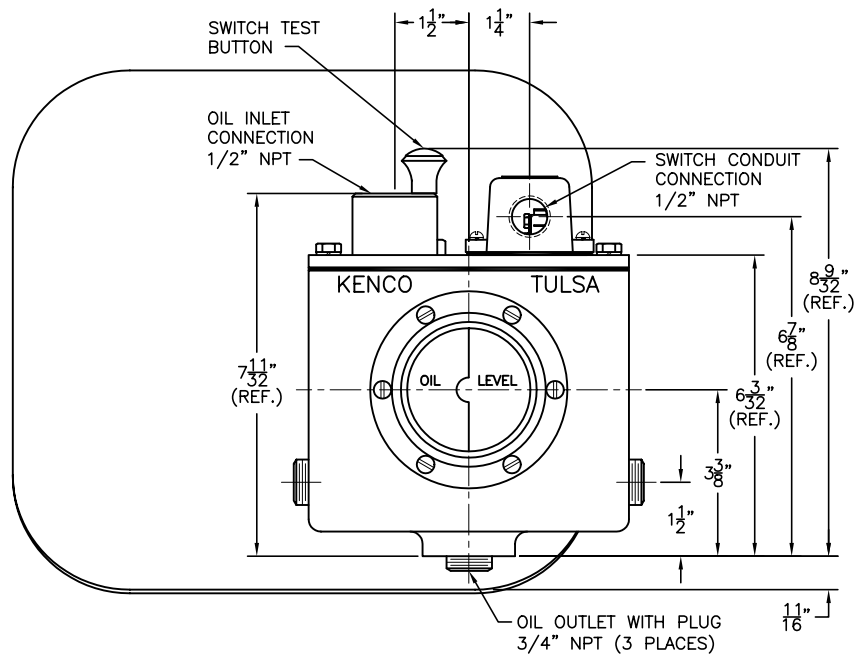
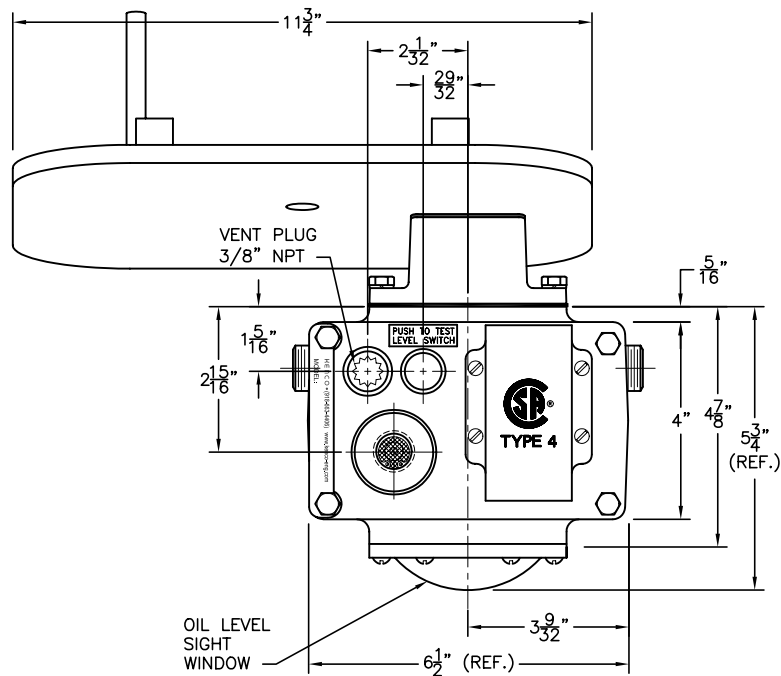

DIMENSIONS ARE FOR REFERENCE PURPOSES ONLY AND ARE SUBJECT TO CHANGE AT ANY TIME WITHOUT NOTICE.
 COPYRIGHT © 2003-KENCO INTERNATIONAL, INC.-ALL RIGHTS RESERVED

WAUKESHA VHP ENGINES
 F2895, F3251, F5108, L5790, AND L7042
 (Supplied with all mounting hardware/seals)

REV.	DATE	BY	ECN	EXPLANATION:	KENCO ENGINEERING COMPANY TULSA, OKLAHOMA
					DATE: 02-04-03 SHEET: 1 OF 1 DRAWING NUMBER
					DRN. BY: DS CHKD. BY: C-44759
					SCALE: NONE REVISION: