

**ORDERING INFORMATION**

MODEL NUMBER	TANK MATERIAL	SEAL MATERIAL	SCALE CALIBRATION
15843	CS OR SS	A, B, E, V OR T	SEE TABLE BELOW

EXAMPLE MODEL NUMBER: 15843-SS-V-GPH

SCALE CALIBRATION OPTIONS / DEFINITIONS	MAXIMUM PUMPING RATE/GAUGE VOLUME	SCALE CALIBRATION INCREMENT VALUE
GPH=GALLONS PER HOUR	2.5	0.05
LPH=LITERS PER HOUR	9.46	0.2
GPD=GALLONS PER DAY	60	1
LPD=LITERS PER DAY	227.12	5
GBV=GALLONS BY VOLUME	0.04	0.001
LBV=LITERS BY VOLUME	0.16	0.005

NOTE: GPH/LPH/GPD/LPD SCALES ARE BASED ON A ONE MINUTE TEST.  
WETTED PARTS: TANK, SIGHT TUBE AND SIGHT TUBE O-RING SEALS

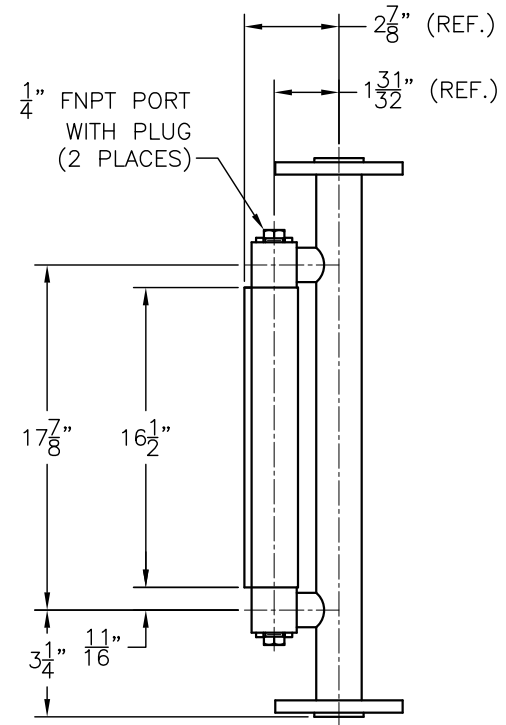
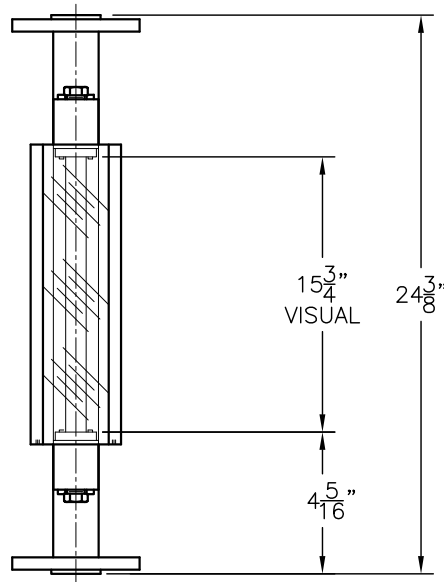
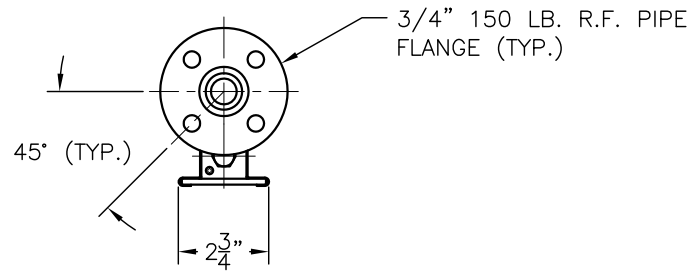

DIMENSIONAL NOTE:  
DIMENSIONS ARE FOR REFERENCE PURPOSES ONLY AND ARE SUBJECT TO CHANGE AT ANY TIME WITHOUT NOTICE.

INFORMATION IS PROPRIETARY TO KENCO ENGINEERING CO.

**PART NUMBER AND MATERIAL DESIGNATION:**

DRAWING NO. MODEL NO. MATERIAL:  
 C-15843-CS 15843-CS (CARBON STEEL TANK WITH 316/316L STAINLESS STEEL WETTED PARTS ON SIGHT GAUGE)  
 C-15843-SS 15843-SS (316/316L STAINLESS STEEL CONSTRUCTION)

REV.	DATE	BY	CHKD.	ECN	EXPLANATION:
A	06-03-93	RC	-	-	ITEM 4 P/N WAS B-14109
B	12-14-94	RC	-	-	ITEM 4 P/N WAS A-18954, MAT'L WAS 6061-T6 ALUM.
C	06-24-05	DS	KI	-	ITEM 1 P/N WAS C-15863
D	01-02-07	DS	-	-	REDRAWN; WAS HAND DWG.; ITEM 2 DESCRIPTION WAS PYREX GAUGE GLASS
E	05-03-10	DS	PAS	000008	ITEM 6 WAS P-13698; ADDED SHEET 2 OF 2; ADDED 13114-A

**KENCO ENGINEERING COMPANY**  
TULSA, OKLAHOMA

POT, CALIBRATION (OUTLINE)  
MODEL NO. 15843

DATE: 11-15-91 SHEET: 1 OF 2 DRAWING NUMBER  
 DRN. BY: RC CHKD. BY: C-15843  
 SCALE: NONE REVISION: E