

OIL LEVEL CONTROLLERS AND OIL LEVEL SWITCHES

FEATURES:

- Reduces maintenance by maintaining a constant oil level
- Protects against lubrication failure
- Controller mechanism fully removable without draining oil
- Easy view convex sight window
- Low to high pressure applications
- Oil inlet allows for piping configurations from any direction
- Oil outlets on either side of housing and in the bottom to allow for various piping configurations
- Easy access to switch float through 3/8" vent hole in top of housing for simple testing of switch operation
- Direct mount adapters eliminate equalizing problems and reduce installation costs
- CSA and ATEX explosion proof certification for hydrogen gas environments on KLCE/KHL/KSHL/KSLL/KES models
- Oil level controllers for synthetic oil applications

APPLICATIONS:

- Stationary engines
- Stationary compressors
- Mechanical lubricators
- Pumps

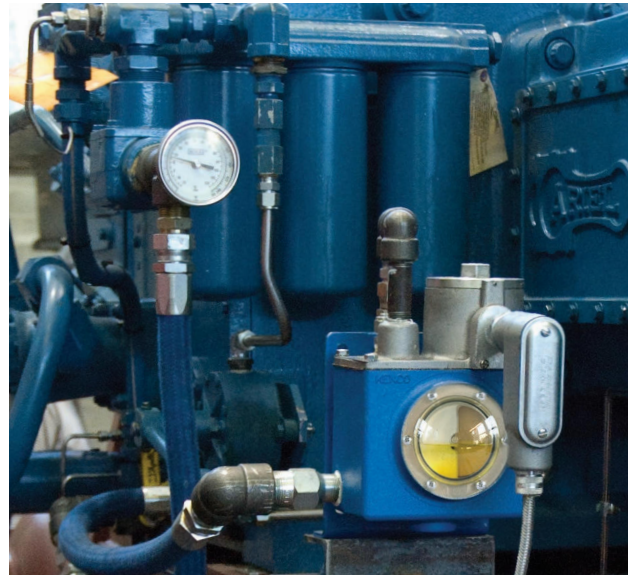

OPERATING PRINCIPLE FOR OIL LEVEL CONTROLLERS

Kenco oil level controllers are designed to maintain the running oil level in the crankcase of stationary engines, compressors, and mechanical lubricator boxes. The Kenco oil controller works in conjunction with an overhead oil supply system which feeds the oil level controller. As the oil is consumed, the oil controller supplies the required oil. The oil controller controls the amount of oil in the crankcase by a float controlled valve. The valve opens and closes as oil is needed in the crankcase to provide a constant oil level.

OPERATING PRINCIPLE FOR OIL LEVEL SWITCHES

Oil level switches are designed as a safety device for the stationary engine or compressor. The oil level switch monitors the oil level in the crankcase. The level within the crankcase directly corresponds with the oil level in the oil level switch housing. The engine or compressor constantly consumes the oil from the crankcase. If the oil level in the crankcase drops past the designated level, the switch will trip and trigger an alarm. Depending on which configuration you have, the switch will trip for high/low level conditions.

Featured above at right and on the cover: KLCE-9 is an oil level controller with an electric switch in an explosion proof enclosure with a slotted universal mounting bracket.

Featured at right: KLCM-9 is an oil level controller with an electric switch in a CSA® Type 4 enclosure with a slotted universal mounting bracket.



MODEL SPECIFICATIONS

MODEL K512 OIL LEVEL CONTROLLER WITH CASE-TO-GROUND ELECTRIC SWITCH; ALSO K512-TB / K512HL / K512HL-TB

APPLICATION OF MODEL K512:

The Kenco K512 utilizes the operating principles of both the oil level controller and the electric switch. The case-to-ground switch and the circuit will remain open until the oil level drops 1/2" below the centerline of sight window. The K512 is for non-hazardous locations and locations where space is limited.

APPLICATION OF MODEL K512-TB:

The Kenco K512-TB is constructed with a switch contact test button to easily check for proper wiring installation and system response to a low oil level condition.

APPLICATION OF MODEL K512HL:

The Kenco K512HL is constructed with one case-to-ground switch contact circuit that remains open until the oil level is 1/2" above or 1/2" below the centerline of sight window.

APPLICATION OF MODEL K512HL-TB:

The Kenco K512HL-TB is constructed with a switch contact test button to easily check for proper wiring installation and system response to a low or high oil level condition.

STANDARD MATERIALS OF CONSTRUCTION:

Valve Seat: Nitrile (Fluorocarbon also available)
Housing and Valve Orifice Material: Aluminum
Float Material: Closed Cell Polyurethane
Oil Inlet Screen: 20 Mesh Brass Cloth
Sight Window: U.V. Stabilized Transparent Nylon or Hermetically Sealed Glass (optional)

PROCESS CONNECTIONS:

Oil Inlet Connection Size: 1/2" FNPT
Oil Outlet Connection Sizes:
(2) 1/2" FNPT Side Ports
(1) 3/4" FNPT Bottom Port

OIL INLET DATA:

Static Head Pressure Range: 2–12 Feet
No High Pressure Models Available

FLOW RATE TEST RESULTS:

(Tested at 2' of Head using Mobil Pegasus 805 40 wt. oil at temperatures shown below)
20°-30° F: 10.96 GPD
30°-40° F: 14.14 GPD
40°-50° F: 16.76 GPD

ELECTRIC SWITCH SPECIFICATIONS:

Switch Trip Point: See Application Notes
Switch Rating: 2 amps, 30 VAC/VDC
Max. Temp: 180° F/82° C
Electrical Connection Size: 1/2" FNPT
Circuitry: Case-To-Ground

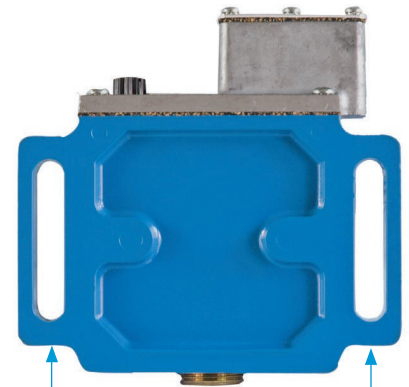
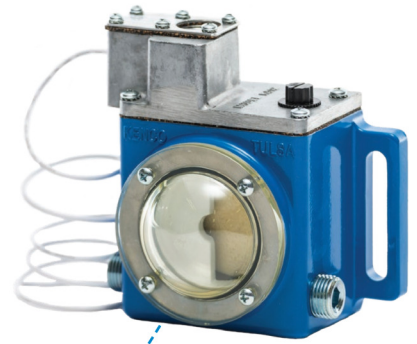

2-9/16" LONG SLOTS ALLOW FOR EASY HEIGHT ADJUSTMENT

MODEL KLC OIL LEVEL CONTROLLER

APPLICATION OF MODEL KLC:

To supply and control the amount of oil in the crankcase.

STANDARD MATERIALS OF CONSTRUCTION:

Valve Seat: Nitrile (Fluorocarbon also available)
Housing and Valve Orifice Material: Aluminum
Float Material: Closed Cell Polyurethane
Oil Inlet Screen: 20 Mesh Brass Cloth
Sight Window: U.V. Stabilized Transparent Nylon or Hermetically Sealed Glass (optional)

FLOW RATE TEST RESULTS:

(Standard unit tested at 32°F, SAE 30)
2' Head: 1.45 GPH
4' Head: 2.46 GPH
6' Head: 3.49 GPH
(HPA unit tested at 32°F, SAE 30)
10 psi: 4.09 GPH
(HPB unit tested at 32°F, SAE 30)
36 psi: 3.38 GPH
70 psi: 6.92 GPH

ALSO AVAILABLE:

SYN: Synthetic Oil Applications—Contact Kenco with Type and Specific Gravity of oil used in the application.

PROCESS CONNECTIONS:

Oil Inlet Connection Size: 1/2" FNPT
Oil Outlet Connection Size: (3) 3/4" FNPT

OIL INLET DATA:

Static Head Pressure Range: 2–25 Feet
High Pressure Models:
HPA: 10–35 psi
HPB: 36–70 psi



MODEL SPECIFICATIONS

MODEL KLCE OIL LEVEL CONTROLLER WITH ELECTRIC SWITCH IN EXPLOSION PROOF ENCLOSURE; ALSO KHL / KSHL / KSLL

APPLICATION OF MODEL KLCE:

The Kenco KLCE utilizes the operating principles of both the oil level controller and the electric switch. Switch trips when oil level drops 3/4" below centerline of sight window.

APPLICATION OF MODEL KHL:

The Kenco KHL is constructed with one level switch, which will alarm at 3/4" above centerline of sight window, and will also alarm at 3/4" below centerline of sight window.

APPLICATION OF MODEL KSHL:

The Kenco KSHL is constructed with 2 independent switches, one for high level alarm 3/4" above centerline of sight window and another for low level alarm at 3/4" below centerline of sight window.

APPLICATION OF MODEL KSLL:

The Kenco KSLL is constructed with 2 independent switches for low level trip points of 5/8" and 7/8" below centerline of sight window.

STANDARD MATERIALS OF CONSTRUCTION:

Valve Seat: Nitrile (Fluorocarbon also available)
Housing and Valve Orifice Material: Aluminum
Float Material: Closed Cell Polyurethane
Oil Inlet Screen: 20 Mesh Brass Cloth
Sight Window: U.V. Stabilized Transparent Nylon or Hermetically Sealed Glass (optional)

MODEL KLCM OIL LEVEL CONTROLLER WITH ELECTRIC SWITCH IN CSA® TYPE 4 ENCLOSURE

APPLICATION OF MODEL KLCM:

The Kenco KLCM utilizes the operating principles of both the oil level controller and the electric switch. Switch trips when oil level drops 3/4" below centerline of sight window. The KLCM is for intrinsically safe applications with an approved safety barrier.

STANDARD MATERIALS OF CONSTRUCTION:

Valve Seat: Nitrile (Fluorocarbon also available)
Housing and Valve Orifice Material: Aluminum
Float Material: Closed Cell Polyurethane
Oil Inlet Screen: 20 Mesh Brass Cloth
Sight Window: U.V. Stabilized Transparent Nylon or Hermetically Sealed Glass (optional)

PROCESS CONNECTIONS:

Oil Inlet Connection Size: 1/2" FNPT
Oil Outlet Connection Size: (3) 3/4" FNPT

OIL INLET DATA:

Static Head Pressure Range: 2–25 Feet
High Pressure Models:
HPA: 10–35 psi
HPB: 36–70 psi

PROCESS CONNECTIONS:

Oil Inlet Connection Size: 1/2" FNPT
Oil Outlet Connection Size: (3) 3/4" FNPT

OIL INLET DATA:

Static Head Pressure Range: 2-25 Feet
High Pressure Models:
HPA: 10–35 psi
HPB: 36–70 psi

FLOW RATE TEST RESULTS:

(Standard unit tested at 32°F, SAE 30)
2' Head: 1.45 GPH
4' Head: 2.46 GPH
6' Head: 3.49 GPH
(HPA unit tested at 32°F, SAE 30)
10 psi: 4.09 GPH
(HPB unit tested at 32°F, SAE 30)
36 psi: 3.38 GPH
70 psi: 6.92 GPH

ELECTRIC SWITCH SPECIFICATIONS:

Switch Trip Point: See Application Notes
Switch Rating: 15 amp, 125/250/480 VAC
0.5 amp, 125 VDC; 0.25 amp, 250 VDC
1/8 hp, 125 VAC; 1/4 hp, 250 VAC
Max. Temp: 180°F/ 82°C
Electrical Connection Size: 1/2" FNPT
Circuitry: Single Pole Double Throw

FLOW RATE TEST RESULTS:

(Standard unit tested at 32°F, SAE 30)
2' Head: 1.45 GPH
4' Head: 2.46 GPH
6' Head: 3.49 GPH
(HPA unit tested at 32°F, SAE 30)
10 psi: 4.09 GPH
(HPB unit tested at 32°F, SAE 30)
36 psi: 3.38 GPH
70 psi: 6.92 GPH

ELECTRIC SWITCH SPECIFICATIONS:

Switch Trip Point: See Application Note
Switch Rating: 11 amp, 277 VAC
0.5 amp, 125 VDC
0.25 amp, 250 VDC
1/3 hp, 125/250 VAC
Max. Temp: 180°F/ 82°C
Electrical Connection Size: 1/2" FNPT
Circuitry: Single Pole Double Throw
Switch Test Button: Standard



CLASS I,
DIV. 1 & 2,
GRPS. B,C,D
T-Code T5



II 2 G
Ex d IIB+H2 T5 Gb
-35° C ≤ Tamb ≤ + 85° C
KEMA 07ATEX0129X

ALSO AVAILABLE:

DPDT: Double Pole Double Throw Switch (KLCE/KHL only)
SYN: Synthetic Oil Applications—Contact Kenco with Type and Specific Gravity of oil used in the application.



TYPE 4

ALSO AVAILABLE:

SYN: Synthetic Oil Applications—Contact Kenco with Type and Specific Gravity of oil used in the application.

MODEL SPECIFICATIONS

MODEL KES ELECTRIC SWITCH IN EXPLOSION PROOF ENCLOSURE; ALSO KHL-ES / KSHL-ES / KSL-ES

APPLICATION OF MODEL KES:

The Kenco KES monitors the oil level in the crankcase and signals shut down in case of low oil level. Switch trips when oil level drops 3/4" below centerline of sight window. It has no oil level controller function.

APPLICATION OF MODEL KHL-ES:

The Kenco KHL-ES is constructed with one level switch, which will alarm at 3/4" above centerline of sight window, and will also alarm at 3/4" below centerline of sight window.

APPLICATION OF MODEL KSHL-ES:

The Kenco KSHL-ES is constructed with 2 independent switches, one for high level alarm 3/4" above centerline of sight window and another for low level alarm at 3/4" below centerline of sight window.

APPLICATION OF MODEL KSL-ES:

The Kenco KSL-ES is constructed with 2 independent switches for low level trip points of 5/8" and 7/8" below centerline of sight window.

STANDARD MATERIALS OF CONSTRUCTION:

Housing Material: Aluminum
Float Material: Closed Cell Polyurethane
Sight Window: U.V. Stabilized Transparent Nylon or Hermetically Sealed Glass (optional)

PROCESS CONNECTIONS:

Oil Outlet Connection Size: (3) 3/4" FNPT

ELECTRIC SWITCH SPECIFICATIONS:

Switch Trip Point: See Application Notes
Switch Rating: 15 amp, 125/250/480 VAC
0.5 amp, 125 VDC; 0.25 amp, 250 VDC
1/8 hp, 125 VAC; 1/4 hp, 250 VAC
Max. Temp: 180°F/ 82°C
Electrical Connection Size: 1/2" FNPT
Circuitry: Single Pole Double Throw

ALSO AVAILABLE:

DPDT: Double Pole Double Throw Switch (KES/KHL-ES Only)
SYN: Synthetic Oil Applications—Contact Kenco with Type and Specific Gravity of oil used in the application.



 C US
CLASS I,
DIV. 1 & 2,
GRPS. B,C,D
T-Code T5

 0344
 II 2 G
Ex d IIB+H2 T5 Gb
-35° C ≤ Tamb ≤ + 85° C
KEMA 07ATEX0129X



OPTIONAL GLASS
SIGHT WINDOW

*MODEL KLCE-GW EXAMPLE SHOWN

MODEL KLCP OIL LEVEL CONTROLLER WITH PNEUMATIC SWITCH

APPLICATION OF MODEL KLCP:

The Kenco KLCP utilizes the operating principles of both the oil level controller and the pneumatic switch. Switch opens when oil level drops 3/4" below centerline of sight window. The KLCP is for remote or offshore locations with no electric power.

STANDARD MATERIALS OF CONSTRUCTION:

Valve Seat: Nitrile (Fluorocarbon also available)
Housing and Valve Orifice Material: Aluminum
Float Material: Closed Cell Polyurethane
Oil Inlet Screen: 20 Mesh Brass Cloth
Sight Window: U.V. Stabilized Transparent Nylon or Hermetically Sealed Glass (optional)

PROCESS CONNECTIONS:

Oil Inlet Connection Size: 1/2" FNPT
Oil Outlet Connection Size: (3) 3/4" FNPT

OIL INLET DATA:

Static Head Pressure Range: 2–25 Feet
High Pressure Models:
HPA: 10–35 psi
HPB: 36–70 psi

FLOW RATE TEST RESULTS:

(Standard unit tested at 32°F, SAE 30)
2' Head: 1.45 GPH
4' Head: 2.46 GPH
6' Head: 3.49 GPH
(HPA unit tested at 32°F, SAE 30)
10 psi: 4.09 GPH
(HPB unit tested at 32°F, SAE 30)
36 psi: 3.38 GPH
70 psi: 6.92 GPH

PNEUMATIC SWITCH SPECIFICATIONS:

Switch Trip Point: See Application Note
Maximum Air Valve Inlet Pressure: 100 psi
Max. Temp: 180°F/ 82°C
Air Inlet Connection Size: 1/4" FNPT
Air Exhaust Connection: 1/4" O.D.
Tube X 1/8" MNPT Tube Fitting
Air Valve Type: 2-way, 2-Position
Switch Test Button: Standard

ALSO AVAILABLE:

SYN: Synthetic Oil Applications—Contact Kenco with Type and Specific Gravity of oil used in the application.



MODEL KPS PNEUMATIC OIL LEVEL SWITCH

Same as model KLCP except with no oil level controller function.

MODEL DIMENSIONS

(REFER TO KENCO WEBSITE FOR MODELS NOT SHOWN)

Model K512 / K512-TB / K512HL / K512HL-TB Oil Level Controller with Case-to-Ground Electric Switch Contact

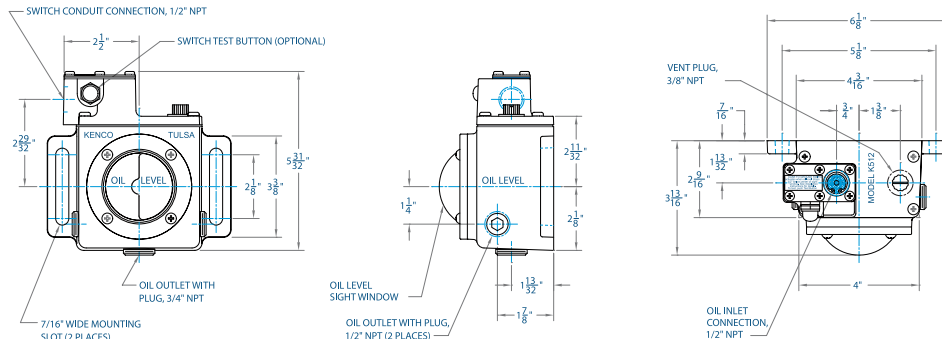

Model KLCE / *KES / KHL / *KHL-ES / KSHL / *KSHL-ES / KSLL / *KSLL-ES Oil Level Controllers with Switch in Explosion Proof Enclosure
 *Models KES / KHL-ES / KSHL-ES / KSLL-ES are Electric Oil Level Switches Only and have No Oil Inlet Connection and No Oil Level Controller Function

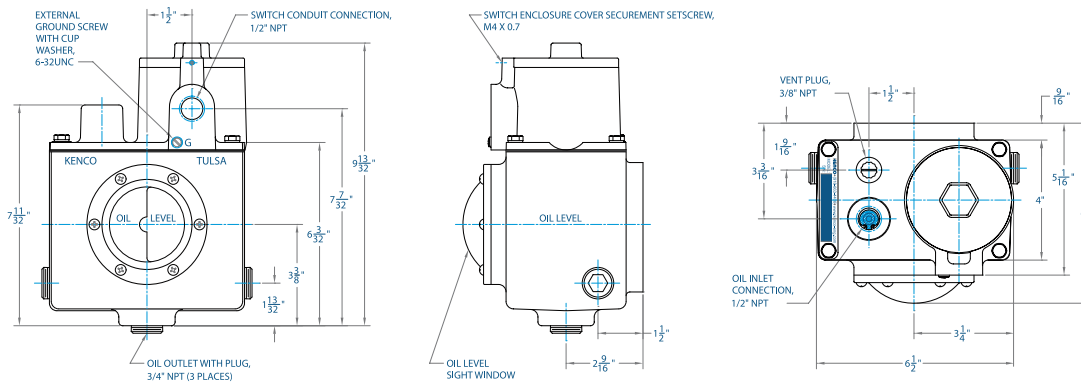

Model KLCP Oil Level Controller with Pneumatic Oil Level Switch

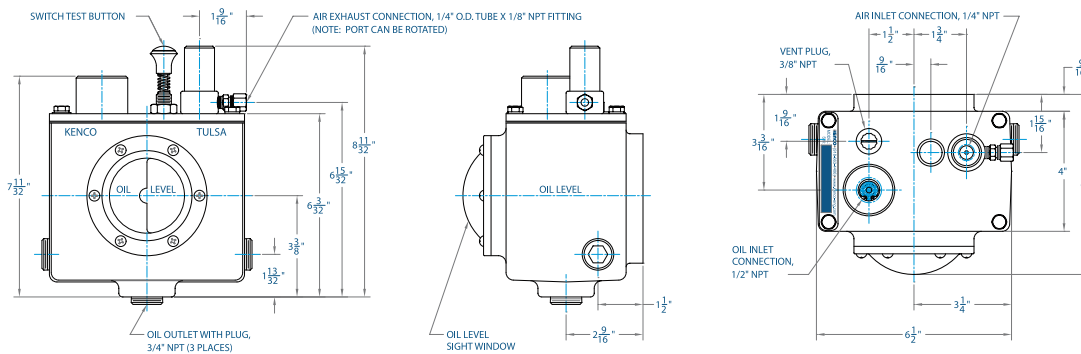

Model KLCM Oil Level Controller with Electric Switch in CSA® Type 4 Enclosure

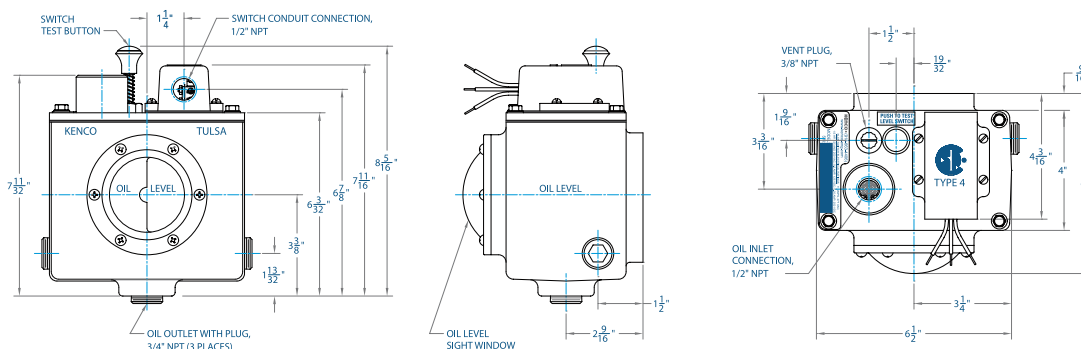

Note: Dimensions are for reference purposes only and are subject to change at any time without notice.

REPLACEMENT KITS

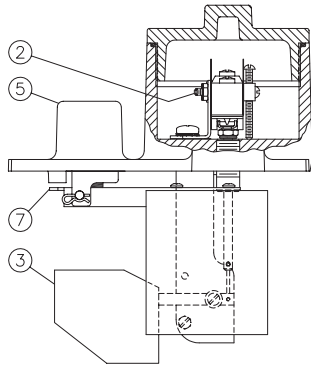

MODEL KLCE PARTS KITS

Kit 1: All Working Parts Kit Order #RK-KLCE

- Consists of:
- 1-Cover Plate Assembly As Shown Above
 - 1-Cover Plate Gasket
 - 4-Mounting Bolts
 - 1-Vent Plug

Kit 2: Switch Kit Order #MS-KLCE

- Consists of:
- 1-Switch Assembly With Bracket
 - 1-Switch Bracket Isolator
 - 2-Mounting Screws

Kit 3: Switch Float Kit Order #MF-KLCE

- Consists of:
- 1-Switch Float Assembly with Bracket
 - 2-Mounting Screws
 - 1-Switch Push Rod Retainer Wire

Kit 4: Controller Gasket / Seal Kit Order #GS-KLCE

- Consists of:
- 1-Cover Plate Gasket
 - 1-Sight Window O-Ring Seal
 - 1-Oil Inlet Float Seal
 - 1-Switch Enclosure O-Ring Seal
 - 1-Switch Push Rod O-Ring Seal

Kit 5: Oil Inlet Housing Kit Order #OI-KLCE

- Consists of:
- 1-Oil Inlet Screen
 - 1-Screen Retainer Ring

Kit 6: Sight Window Kit Order #GL-KLC Order #GL-KLC-GW

- Consists of:
- 1-Sight Window
 - 1-Sight Window O-Ring Seal
 - 6-Mounting Screws

Kit 7: Oil Inlet Float Kit Order #OF-KLC Order #OF-KLC-HPA Order #OF-KLC-HPB

- Consists of:
- 1-Float Assembly With Seal
 - 1-Float Hinge Bracket
 - 2-Mounting Screws
 - 1-Oil Inlet Valve Orifice
 - 1-Clevis Pin
 - 1-Hitch Pin Clip

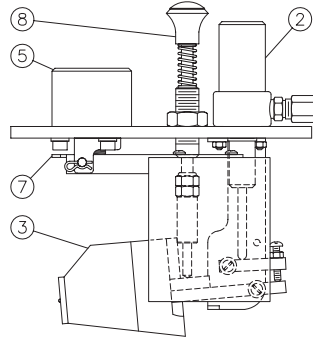

MODEL KLCP PARTS KITS

Kit 1: All Working Parts Kit Order #RK-KLCP

- Consists of:
- 1-Cover Plate Assembly As Shown Above
 - 1-Cover Plate Gasket
 - 4-Mounting Bolts
 - 1-Vent Plug

Kit 2: Air Valve Kit Order #AV-KLCP

- Consists of:
- 1-Complete Air Valve Assembly
 - 1-Exhaust Ring
 - 1-Exhaust Ring O-Ring Seal
 - 1-Air Exhaust Connector
 - 1-Actuator Rod

Kit 3: Air Valve Float Kit Order #AF-KLCP

- Consists of:
- 1-Air Valve Float Assembly with Bracket
 - 2-Mounting Screws
 - 2-Hexagon Nuts

Kit 4: Controller Gasket / Seal Kit Order #GS-KLCP

- Consists of:
- 1-Cover Plate Gasket
 - 1-Sight Window O-Ring Seal
 - 1-Oil Inlet Float Seal
 - 1-Oil Inlet Housing O-Ring Seal
 - 1-Air Valve Internal O-Ring Seal
 - 1-Test Button Push Rod O-Ring Seal
 - 1-Air Valve Exhaust Ring O-Ring Seal

Kit 5: Oil Inlet Housing Kit Order #OI-KLC

- Consists of:
- 1-Oil Inlet Screen
 - 1-Screen Retainer Ring
 - 1-Oil Inlet Housing
 - 1-Housing O-Ring Seal
 - 3-Mounting Screws
 - 3-Lock Washers

Kit 6: Sight Window Kit Order #GL-KLC Order #GL-KLC-GW

- Consists of:
- 1-Sight Window
 - 1-Sight Window O-Ring Seal
 - 6-Mounting Screws

Kit 7: Oil Inlet Float Kit Order #OF-KLC Order #OF-KLC-HPA Order #OF-KLC-HPB

- Consists of:
- 1-Float Assembly With Seal
 - 1-Float Hinge Bracket
 - 2-Mounting Screws
 - 1-Oil Inlet Valve Orifice
 - 1-Clevis Pin
 - 1-Hitch Pin Clip

Kit 8: Test Button Kit Order #TB-KLCP

- Consists of:
- 1-Complete Test Button Assembly

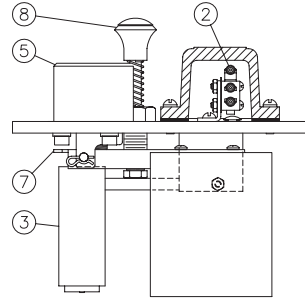

MODEL KLCP PARTS KITS

Kit 1: All Working Parts Kit Order #RK-KLCM

- Consists of:
- 1-Cover Plate Assembly As Shown Above
 - 1-Cover Plate Gasket
 - 4-Mounting Bolts
 - 1-Vent Plug

Kit 2: Switch Kit Order #MS-KLCM

- Consists of:
- 1-Switch Assembly With Bracket
 - 2-Switch Assembly Mounting Screws
 - 1-Switch Enclosure Gasket
 - 4-Switch Enclosure Mounting Screws
 - 1-Ground Wire with Ring Terminal

Kit 3: Switch Float Kit Order #MF-KLCM

- Consists of:
- 1-Switch Float Assembly with Bracket
 - 2-Mounting Screws
 - 1-Switch Push Rod Retainer Wire

Kit 4: Controller Gasket / Seal Kit Order #GS-KLCM

- Consists of:
- 1-Cover Plate Gasket
 - 1-Sight Window O-Ring Seal
 - 1-Oil Inlet Float Seal
 - 1-Oil Inlet Housing O-Ring Seal
 - 1-Switch Push Rod O-Ring Seal
 - 1-Test Button Push Rod O-Ring Seal
 - 1-Switch Enclosure Gasket

Kit 5: Oil Inlet Housing Kit Order #OI-KLC

- Consists of:
- 1-Oil Inlet Screen
 - 1-Screen Retainer Ring
 - 1-Oil Inlet Housing
 - 1-Housing O-Ring Seal
 - 3-Mounting Screws
 - 3-Lock Washers

Kit 6: Sight Window Kit Order #GL-KLC Order #GL-KLC-GW

- Consists of:
- 1-Sight Window
 - 1-Sight Window O-Ring Seal
 - 6-Mounting Screws

Kit 7: Oil Inlet Float Kit Order #OF-KLC Order #OF-KLC-HPA Order #OF-KLC-HPB

- Consists of:
- 1-Float Assembly With Seal
 - 1-Float Hinge Bracket
 - 2-Mounting Screws
 - 1-Oil Inlet Valve Orifice
 - 1-Clevis Pin
 - 1-Hitch Pin Clip

Kit 8: Test Button Kit Order #TB-KLCM

- Consists of:
- 1-Complete Test Button Assembly

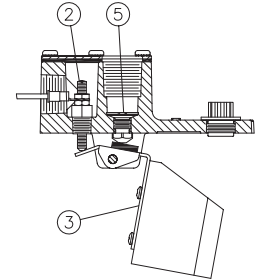

MODEL K512 / K512-TB PARTS KITS

Kit 1: K512 / K512-TB All Working Parts Kit Order #RK-K512 Order #RK-K512-TB

- Consists of:
- 1-Cover Plate Assembly As Shown Above
 - 1-Cover Plate Gasket
 - 4-Mounting Screws
 - 1-Vent Plug

Kit 2: Switch Kit Order #MS-K512

- Consists of:
- 1-Insulator Bushing
 - 1-Set Screw
 - 2-Hexagon Nuts
 - 1-Ring Terminal

Kit 3: Switch Float Kit Order #MF-K512

- Consists of:
- 1-Float Assembly With Seal
 - 1-Clevis Pin
 - 1-Hitch Pin Clip

Kit 4A: K512 Gasket / Seal Kit Order #GS-K512

- Consists of:
- 1-Cover Plate Gasket Set
 - 1-Sight Window O-Ring Seal
 - 1-Oil Inlet Float Seal

Kit 4B: K512-TB Gasket / Seal Kit Order #GS-K512-TB

- Consists of:
- 1-Cover Plate Gasket Set
 - 1-Sight Window O-Ring Seal
 - 1-Oil Inlet Float Seal
 - 1-Test Button O-Ring Seal

Kit 5: Oil Inlet Housing Kit Order #OI-K512

- Consists of:
- 1-Oil Inlet Screen
 - 1-Screen Retainer Ring

Kit 6: Sight Window Kit Order #GL-K512 Order #GL-K512-GW

- Consists of:
- 1-Sight Window
 - 1-Sight Window O-Ring Seal
 - 4-Mounting Screws

Kit 7: K512-TB Test Button Kit Order #TB-K512

- Consists of:
- 1-Complete Test Button Assembly

Model K512HL and K512HL-TB Kits
Refer to Kenco Website

KENCO ADAPTERS

CONTROLLER-TO-CRANKCASE MOUNTING ADAPTERS

(Note: "∨" denotes controller mounting surface.)

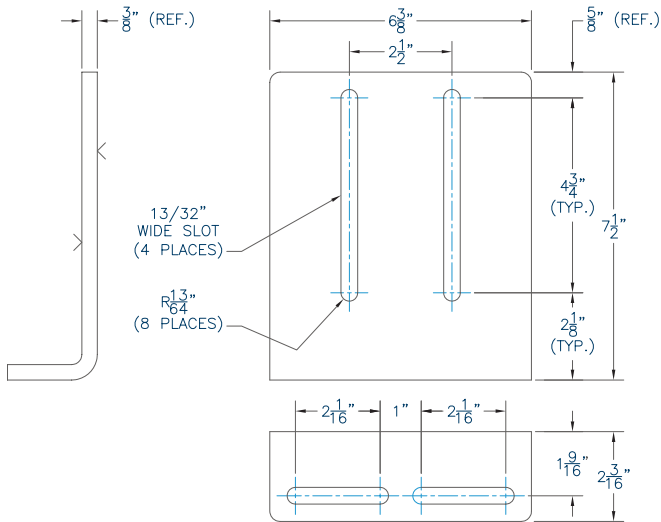

TYPE 9

Universal Mounting Bracket for Any Engine

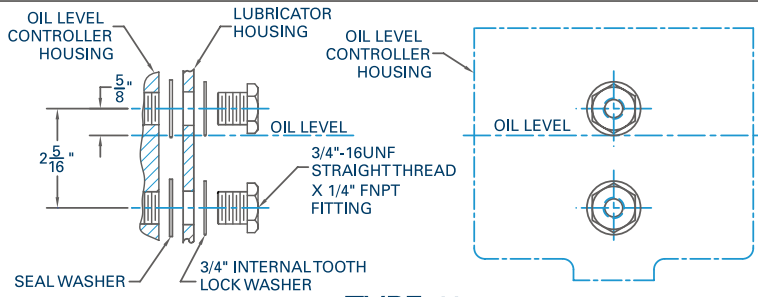

TYPE 11

For Mechanical Lubricator
(Drill $\phi 25/32$ " holes in lubricator housing to mount)

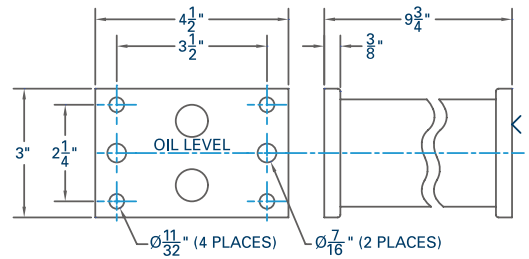

TYPE 24

For Ariel (2/4 Throw) JGE, JGH, JGK, JGT, KBK and KBT Compressors

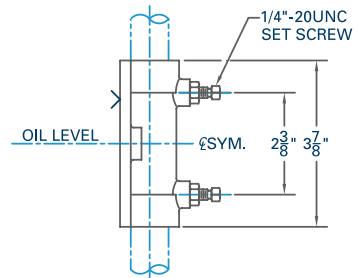
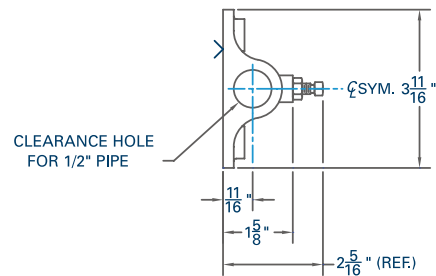

TYPE 12

For 1/2" Pipe

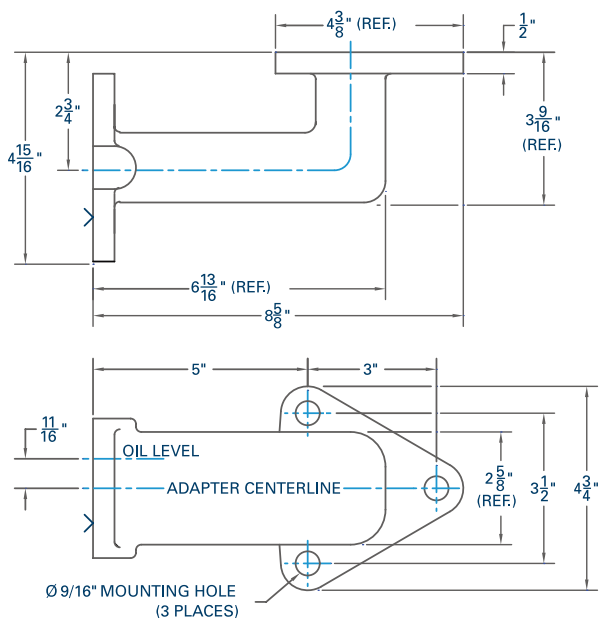

TYPE 14

Cooper Superior Compressor (Formerly White)

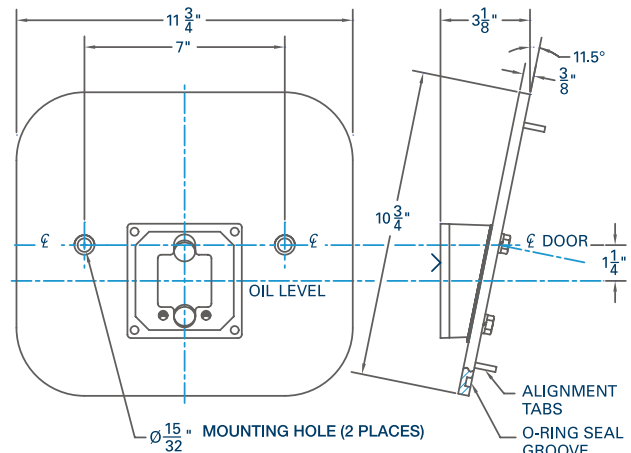

TYPE 27

Waukesha VHP Engines
(Supplied with all mounting hardware/seals)

TYPE 17

Similar to type 27 except for use with old Waukesha engines having inspection door with (1) mounting bolt

CONTROLLER-TO-CRANKCASE MOUNTING ADAPTERS

Number	Description
-1	Clark MA & CFA
-2	Clark HMB & TMP
-3	Clark RA, HRA, HBA, HCA, HLA, TCV & TLA
-4*	Ingersoll-Rand SVG & KVS
-5	Ingersoll-Rand KVG
-6	Cooper-Bessemer GMW
-7	Cooper-Bessemer GMV
-8	Cooper-Bessemer GMX
-9*	Universal Mounting Adapter
-9MS *	KLCE type housing with four 3/8"-16UNC integral mounting studs for use with -9 universal mounting adapter or any mounting configuration which incorporates the stud pattern (Note: This option does not include the universal mounting adapter)
-10*	Slotted Adapter for Universal Mounting
-11	Mechanical Lubricator Mounting
-12*	Post Mount For 1/2" Pipe
-14	Cooper Superior Compressor (Formerly White)
-15	Ingersoll-Rand XVG & PVG
-16	Cooper-Bessemer BMV & 275 (Available with varied oil level)
-17	Waukesha VHP Engines F2895, F3521, F5108, L5790 and L7042 (Replaces Inspection Door with Single Bolt Mounting Arrangement)
-18	Waukesha VHP Engines F2895, F3521, F5108, L5790 and L7042 (Same as -17 except with Integral Kenco 1618 Low Flow Meter)
-19	Ingersoll-Rand Rotary
-21	Cooper-Bessemer 2400 Series 6
-23	Ariel KBC (2/4/6 Throw), KBD (2/4/6 Throw) and KBF (2/4/6 Throw) Compressors
-24	Ariel JGE (2/4 Throw), JGH (2/4 Throw), JGK (2/4 Throw), JGT (2/4 Throw), KBK (2/4 Throw) and KBT (2/4 Throw) Compressors
-25	Ariel JGU (2/4/6 Throw), JGZ (2/4/6 Throw), KBB (4/6 Throw) and KBV (4/6 Throw) Compressors
-26	Ariel KBU (2/4/6 Throw) and KBZ (2/4/6 Throw) Compressors
-27	Waukesha VHP Engines F2895, F3521, F5108, L5790, L5794 & L7042 (Replaces Inspection Door with Two Bolt Mounting Arrangement)
-28	Waukesha VHP P9394 Engine (Replaces Inspection Door)
-37	Waukesha P9390 Engine (Replaces Inspection Door)
-38	Waukesha P9390 Engine (Same as -37 except with Integral Kenco 1618 Low Flow Meter)
-39	Waukesha P9390 Engine (Same as -37 except with Integral Kenco 14308 Low Flow Meter)
-40	Waukesha VHP Engines F2895, F3521, F5108, L5790 and L7042 (Same as -17 except with Integral Kenco 14308 Low Flow Meter)
-48A	Ariel JGB (4/6 Throw), JGC (2 Throw), JGD (2 Throw), JGF (2 Throw) and JGV (4/6 Throw) Compressors
-48B	Ariel JGC (4/6 Throw), JGD (4/6 Throw) and JGF (4/6 Throw) Compressors with Standard Shaft Rotation and a Single Chain Drive Ariel JGC (6 Throw), JGD (6 Throw) and JGF (6 Throw) Compressors with Reverse Shaft Rotation and a Dual Chain Drive
-48C	Ariel JGC (4/6 Throw), JGD (4/6 Throw) and JGF (4/6 Throw) Compressors with Reverse Shaft Rotation and a Single Chain Drive Ariel JGC (6 Throw), JGD (6 Throw) and JGF (6 Throw) Compressors with Standard Shaft Rotation and a Dual Chain Drive
-991	Dresser-Rand HOS, HOSS and MOS Compressors
-C33/34*	Caterpillar C3300/3400 Engines
Controller-to-Crankcase Mounting Adapters Specifically for Model K512 Controllers	
-9U*	Universal Mounting Adapter
-A	Arrow C46, C66, C106 and C245
-AJAX	Ajax, Lufkin Made Before 1-1-63, Superior and Other Crosshead Type Engines, and Tri-Plex Pumps With 1/2" Drains
-FM	Fairbanks Morse ZC, 118, 208, 346, 503, and 739
-L-795	Arrow L-795
-ML	For Side Mounting on Mechanical Lubricator when there is No Extra Pump Pocket
-SML	Mounts on the end of the McCord Mechanical Lubricator next to the Filler Cap
-W*	Witte B, C & F28, F32 & F42
-W98*	Witte 98 with Oil Gauge Bolted to Engine

*Indirect mounted controllers/switches require an equalizing line for proper operation.

OPERATING PRINCIPLE

A typical Fire Safe Oil Control System has two spring-loaded, thermally actuated Kenco Fire Safe valves. In the event of a fire, the valve's eutectic fuse element melts and the valves close automatically. This prevents the oil contained inside the crankcase and the oil reserve tank from feeding the fire.

BENEFITS:

- Lower insurance rates
- Protection in case of fire to equipment
- Protection of personnel
- Protection of environment
- Prevents oil supply from feeding a fire

SPECIFICATIONS

- Valve Body: Zinc Plated Carbon Steel (316 S.S. optional)
- Spring: Stainless Steel (Inconel on 10-KFS, 125-KFS, 15-KFS and 20-KFS)
- Valve Plunger: Carbon Steel (316 S.S. optional)
- Seal Material: Fluorocarbon
- Thermal Fuse Melting Temp.: 360°F
- Maximum Working Pressure: 70 psig
- Connection Sizes: 1/2" FNPT, 3/4" FNPT, 1" FNPT, 1-1/4" FNPT, 1-1/2" FNPT and 2" FNPT

TYPICAL INSTALLATION

INLET SIDE:

Install the Model 50-KFS as close to the controller inlet (or Kenco Low Flow Meter) as possible.

OUTLET SIDE:

Install the Model 75-KFS as close to the engine crankcase as possible.

*Note: Flow through valve is bidirectional.

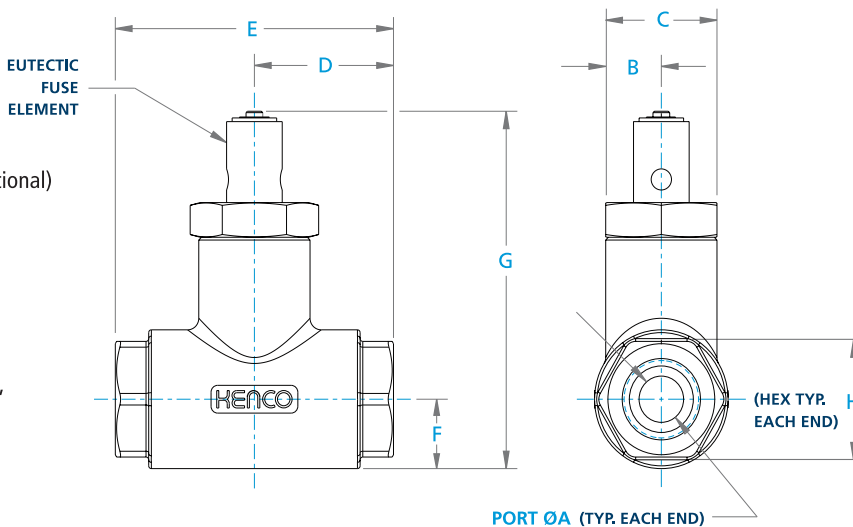

Dimensional Information

Valve Model	50-KFS	75-KFS	10-KFS	125-KFS	15-KFS	20-KFS
Connection Size	1/2" FNPT	3/4" FNPT	1" FNPT	1-1/4" FNPT	1-1/2" FNPT	2" FNPT
A	1/2"	3/4"	1"	1-1/2"	1-1/2"	2"
B	5/8"	3/4"	15/16"	1-1/8"	1-1/8"	1-5/8"
C	1-1/4"	1-1/2"	1-7/8"	2-1/4"	2-1/4"	3-1/4"
D	1-9/16"	1-3/4"	2-1/16"	2-9/16"	2-9/16"	3-7/16"
E	3-1/8"	3-1/2"	4-1/8"	5-1/8"	5-1/8"	6-7/8"
F	3/4"	7/8"	1-1/32"	1-7/16"	1-7/16"	1-7/8"
G (C.S.)	3-7/8"	4-3/8"		7-1/8"	7-1/8"	9-7/16"
G (S.S.)	4-1/8"	4-5/8"	5-7/32"			
H	1-5/16"	1-9/16"	1-3/4"	2-1/2"	2-1/2"	3-5/16"

Note: The model designations shown in the table above represent the order number for standard Carbon Steel Fire Safe valves. To order Stainless Steel Fire Safe valves, add the suffix "-SS" to the end of the order number. (Example: A 1/2" NPT Stainless Steel Model 50-KFS Fire Safe valve would be ordered as 50-KFS-SS)

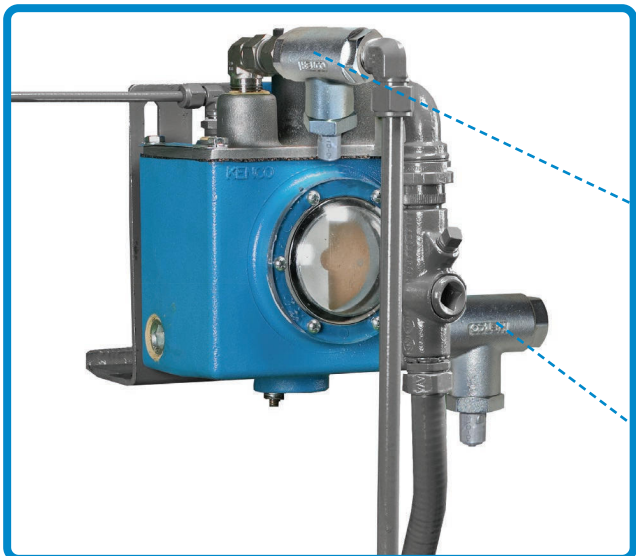

INLET SIDE:

In case of a fire, stops oil from flowing from oil reserve supply.



OUTLET SIDE:

In case of a fire, stops back flow of oil from crank case.

MODEL DESIGNATIONS

Model	Description
KLC	Oil Level Controller (No Switch Function)
KLCE	Oil Level Controller with S.P.D.T. Electric Switch in Explosion Proof Enclosure
KLCE-DPDT	Oil Level Controller with D.P.D.T. Electric Switch in Explosion Proof Enclosure
KES	S.P.D.T. Electric Switch in Explosion Proof Enclosure (No Oil Controller Function)
KES-DPDT	D.P.D.T. Electric Switch in Explosion Proof Enclosure (No Oil Controller Function)
KHL	Oil Level Controller with S.P.D.T. Electric Switch in Explosion Proof Enclosure for Single High Level and Low Level Alarm
KHL-DPDT	Oil Level Controller with D.P.D.T. Electric Switch in Explosion Proof Enclosure for Single High Level and Low Level Alarm
KHL-ES	S.P.D.T. Electric Switch in Explosion Proof Enclosure for Single High Level and Low Level Alarm (No Oil Controller Function)
KHL-ES-DPDT	D.P.D.T. Electric Switch in Explosion Proof Enclosure for Single High Level and Low Level Alarm (No Oil Controller Function)
KSHL	Oil Level Controller with Two S.P.D.T. Electric Switches in Explosion Proof Enclosure for Separate High Level and Low Level Alarms
KSHL-ES	Two S.P.D.T. Electric Switches in Explosion Proof Enclosure for Separate High Level and Low Level Alarms (No Oil Controller Function)
KSLL	Oil Level Controller with Two S.P.D.T. Electric Switches in Explosion Proof Enclosure for Two Separate Low Level Alarms
KSLL-ES	Two S.P.D.T. Electric Switches in Explosion Proof Enclosure for Two Separate Low Level Alarms (No Oil Controller Function)
KLCM	Oil Level Controller with S.P.D.T. Electric Switch in CSA Type 4 Enclosure
KLCP	Oil Level Controller with Pneumatic Switch
KPS	Pneumatic Switch (No Oil Controller Function)
K512	Oil Level Controller with Case-To-Ground Switch Contact
K512-TB	Oil Level Controller with Case-To-Ground Switch Contact and Switch Contact Test Button
K512HL	Oil Level Controller with Case-To-Ground Switch Contact for Single High Level and Low Level Alarm
K512HL-TB	Oil Level Controller with Case-To-Ground Switch Contact for Single High Level and Low Level Alarm and Switch Contact Test Button

ORDERING SYSTEM

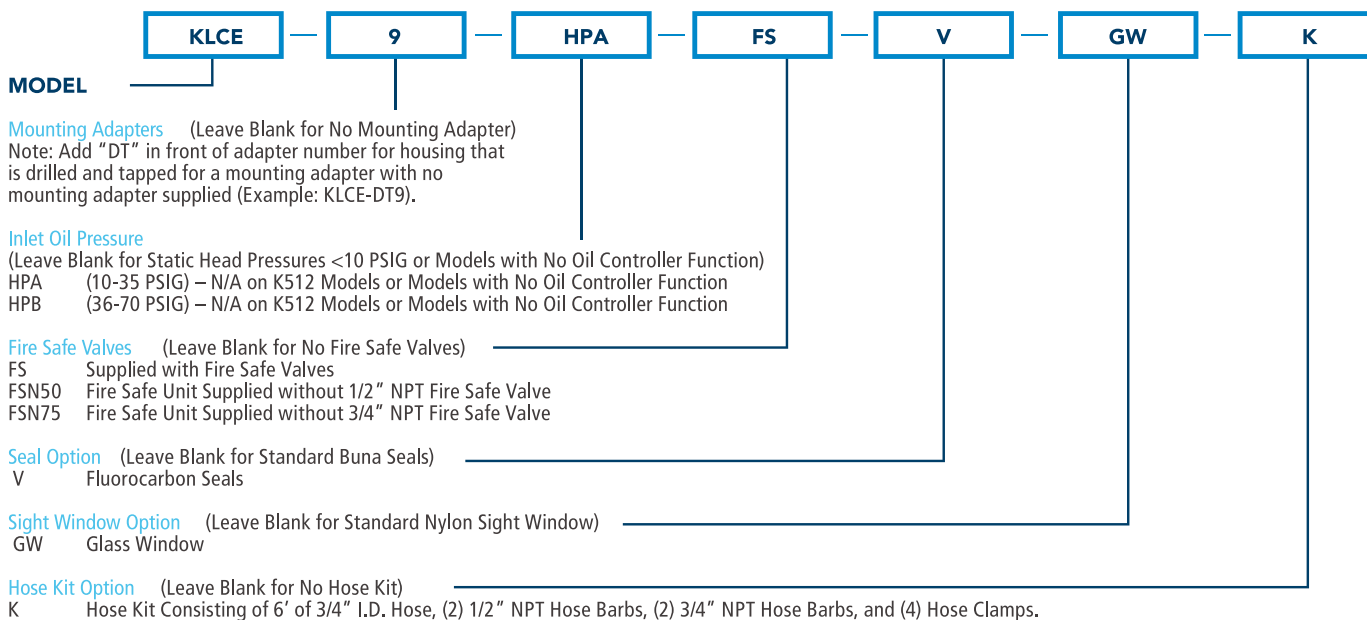

Synthetic Oil Option
 Contact Kenco with the Type and Specific Gravity of synthetic oil being used in the application

Example Order Designation:
 KLCE-9-HPA-FS-V-GW-K is an Oil Level Controller with S.P.D.T. Electric Switch in Explosion Proof Enclosure, a Universal Mounting Adapter, a High Pressure Inlet Valve rated for 10-35 PSIG, Fire Safe Valves, Fluorocarbon Seals, Glass Sight Window, and a Hose Kit.

IN-LUBRICATOR OIL LEVEL CONTROLLER WITH SAFETY SWITCH

MODEL K507L

The standard valve seat material is Nitrile, but may be ordered as Fluorocarbon for other types of lubrication. A 1/2" FNPT oil inlet connection and 1/2" FNPT conduit connection is standard. An optional conduit connection wire sealing cap is available for applications with no conduit. The switch is case-to-ground and the circuit will remain open until the oil supply from the outside source is empty.



MODEL 507K

The standard valve seat material is a chrome steel ball check. Seal materials are Cork Neoprene and Nitrile. A 1/2" FNPT oil inlet connection is standard. The switch is case-to-ground and the circuit will remain open until the oil supply from the outside source is empty.

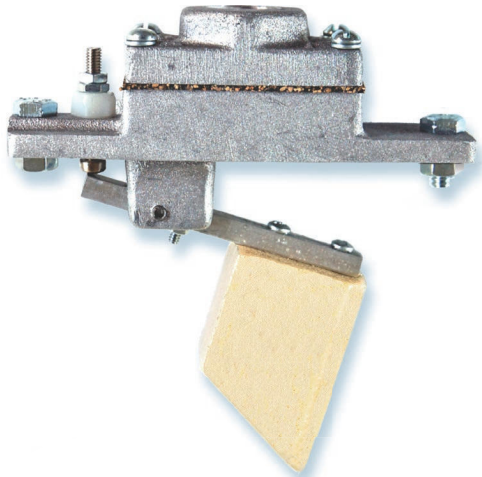

MODEL 507M

The standard valve seat material is Nitrile, but may be ordered as Fluorocarbon for other types of lubrication. A 1/2" FNPT oil inlet connection and 1/2" FNPT conduit connection is standard. The switch is S.P.D.T. and can be wired normally open or normally closed.



APPLICATION:

Series 507 Oil Level Controllers are designed for use in Lincoln, Premier, and Mega Lubricators.

OPERATING PRINCIPLE:

Series 507 Oil Level Controllers automatically monitor and control the amount of oil in the lubricator housing. This keeps all of the working parts including the pump plungers submerged in oil to reduce wear and corrosion. When the level falls below the operational requirement, the low level safety switch will be activated.

FEATURES

- Valve design eliminates lubricator box overfill due to contaminants in the oil
- Controls oil level in lubricator
- Low level safety switch protects against engine and pump repairs due to lubrication failure
- Non-mercury switch will not react to vibration

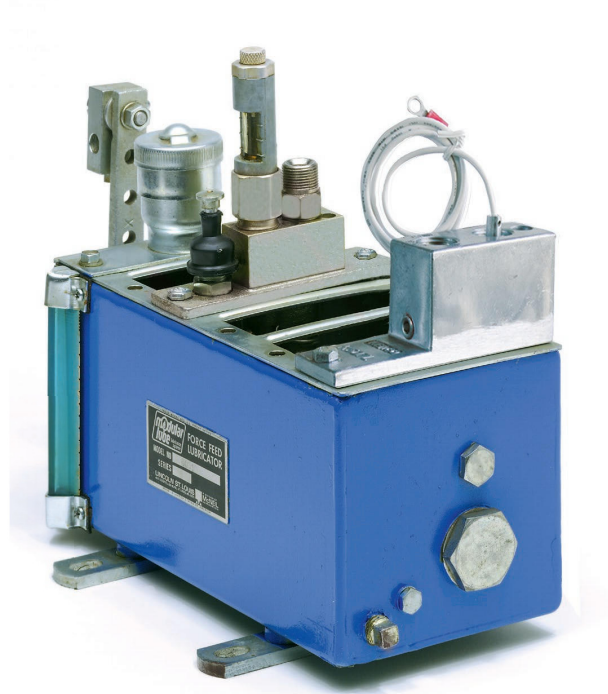

MODEL K507L SHOWN MOUNTED

MODEL K507L

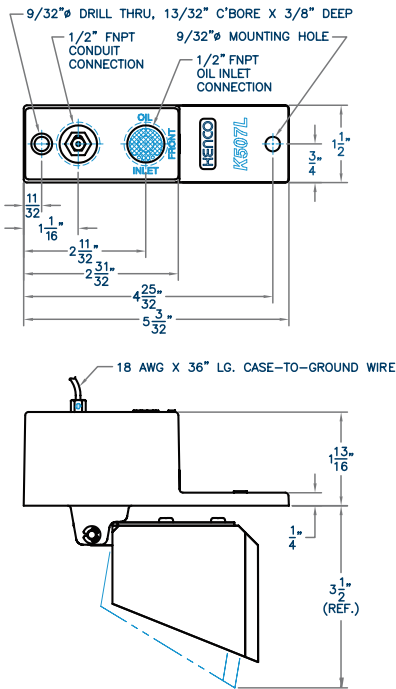

K507L

MATERIALS OF CONSTRUCTION:

- Controller Housing: Aluminum
- Valve Seat: Nitrile
- Optional Valve Seat: Fluorocarbon
- Valve Orifice: Aluminum
- Float: Closed Cell Polyurethane
- Oil Inlet Screen: 20 Mesh Brass

SPECIFICATIONS:

- Switch Trip Point: 3/4" drop in oil level
- Switch Rating: 2 amps, 30 VAC or VDC
- Switch Circuitry: Case-To-Ground
- Electrical Connection: 1/2" FNPT conduit connection with 18 AWG x 36" long wire lead
- Maximum Temperature: 211° F
- Oil Inlet Connection: 1/2" FNPT
- Oil Inlet Pressure using Standard Orifice: 1' to 14" head of oil
- Flow Rate using Standard Orifice tested at 32° F, SAE 30 oil, 2' head: 1.1413 gallons per hour
- Oil Inlet Pressure using Optional High Pressure Orifice: 5 psig to 60 psig
- Flow Rate using Optional High Pressure Orifice tested at 32° F, SAE 30 oil, 5 psig: 0.6425 gallons per hour

ORDERING INFORMATION

- Add suffix "-HP" to model number to designate optional "High Pressure" orifice
- Add suffix "-V" to model number to designate optional "Fluorocarbon" valve seat
- Optional Conduit Connection Wire Sealing Cap (shown at right) to be ordered as a separate line item

MODEL 507K

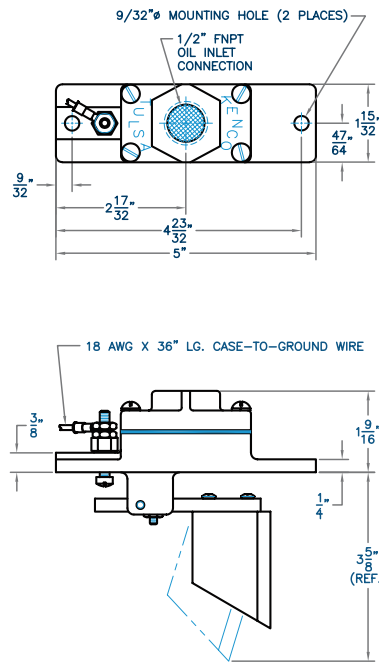

507K

MATERIALS OF CONSTRUCTION:

- Controller Housing: Aluminum
- Valve Seat: Chrome Steel
- Valve Orifice: Aluminum
- Float: Closed Cell Polyurethane
- Oil Inlet Screen: 60 Mesh Brass

SPECIFICATIONS:

- Switch Trip Point: 3/4" drop in oil level
- Switch Rating: 2 amps, 30 VAC or VDC
- Switch Circuitry: Case-To-Ground
- Electrical Connection: 18 AWG x 36" long wire lead
- Maximum Temperature: 211° F
- Oil Inlet Connection: 1/2" FNPT
- Oil Inlet Pressure: 2' to 5' head of oil

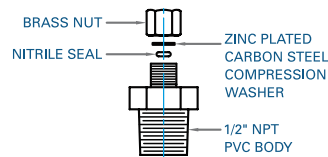

K507L OPTIONAL PART:

- 1/2" NPT Conduit Connection Wire Sealing Cap (Kenco Part Number 51006)

MODEL 507M

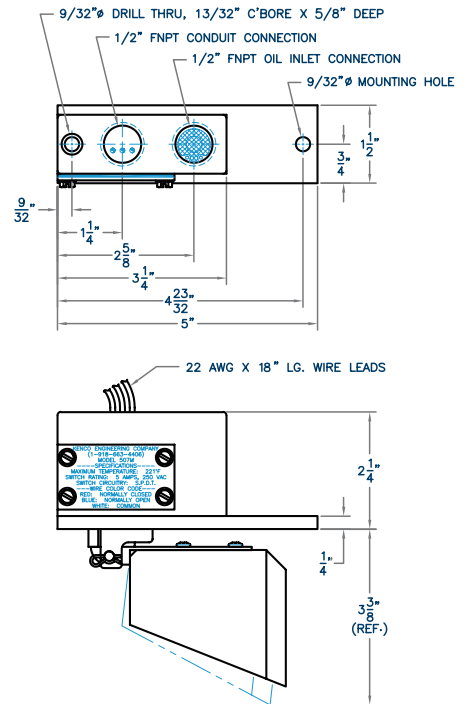

507M

MATERIALS OF CONSTRUCTION:

- Controller Housing: Aluminum
- Valve Seat: Nitrile
- Optional Valve Seat: Fluorocarbon
- Valve Orifice: Aluminum
- Float: Closed Cell Polyurethane
- Oil Inlet Screen: 20 Mesh Brass

SPECIFICATIONS:

- Switch Trip Point: 3/4" drop in oil level
- Switch Rating: 5 amps, 250 VAC
- Switch Circuitry: S.P.D.T.
- Electrical Connection: 1/2" FNPT conduit connection with 22 AWG x 18" long wire leads
- Wire Color Code:
 - Red: Normally Closed
 - Blue: Normally Open
 - White: Common
- Maximum Temperature: 211° F
- Oil Inlet Connection: 1/2" FNPT
- Oil Inlet Pressure using Standard Orifice: 1' to 14" head of oil
- Flow Rate using Standard Orifice tested at 32° F, SAE 30 oil, 2' head: 1.1413 gallons per hour
- Oil Inlet Pressure using Optional High Pressure Orifice: 5 psig to 60 psig
- Flow Rate using Optional High Pressure Orifice tested at 32° F, SAE 30 oil, 5 psig: 0.6425 gallons per hour

ORDERING INFORMATION

- Add suffix "-HP" to model number to designate optional "High Pressure" orifice
- Add suffix "-V" to model number to designate optional "Fluorocarbon" valve seat and seals