

ORDERING INFORMATION			
MODEL NUMBER	TANK MATERIAL	SEAL MATERIAL	SCALE CALIBRATION
15852	CS OR SS	A, B, E, V OR T	SEE TABLE BELOW

EXAMPLE MODEL NUMBER: 15852-SS-V-GPH

SCALE CALIBRATION OPTIONS / DEFINITIONS	MAXIMUM PUMPING RATE/GAUGE VOLUME	SCALE CALIBRATION INCREMENT VALUE
GPH=GALLONS PER HOUR	60	1
LPH=LITERS PER HOUR	227.12	5
GPD=GALLONS PER DAY	1440	25
LPD=LITERS PER DAY	5450.98	100
GBV=GALLONS BY VOLUME	1	0.02
LBV=LITERS BY VOLUME	3.79	0.05

NOTE: GPH/LPH/GPD/LPD SCALES ARE BASED ON A ONE MINUTE TEST.
 WETTED PARTS: TANK, SIGHT TUBE AND SIGHT TUBE O-RING SEALS

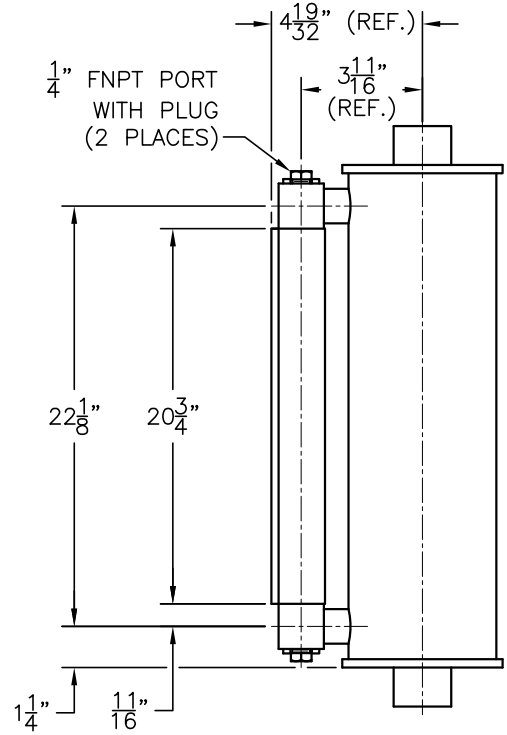

DIMENSIONAL NOTE:
 DIMENSIONS ARE FOR REFERENCE
 PURPOSES ONLY AND ARE SUBJECT TO
 CHANGE AT ANY TIME WITHOUT NOTICE.

INFORMATION IS PROPRIETARY TO KENCO ENGINEERING CO.

PART NUMBER AND MATERIAL DESIGNATION:

DRAWING NO.	MODEL NO.	MATERIAL:
C-15852-CS	15852-CS	(CARBON STEEL TANK WITH 316/316L STAINLESS STEEL WETTED PARTS ON SIGHT GAUGE)
C-15852-SS	15852-SS	(316/316L STAINLESS STEEL WETTED PARTS)
C-15852-S6	15852-S6	(316/316L STAINLESS STEEL CONSTRUCTION)

REV.	DATE	BY	CHKD.	ECN	EXPLANATION:
B	12-14-94	RC	-	-	ITEM 4 P/N WAS A-18954, MAT'L WAS 6061-T6 ALUM.
C	05-03-10	DS	PAS	000008	REDRAWN; WAS HAND DWG.; ITEM 2 DESCRIPTION WAS PYREX GAUGE GLASS ITEM 6 WAS P-13698; ADDED SHEET 2 OF 2; ADDED 13114-A
D	07-17-19	BRC	DS	000299	UPDATED TO REFLECT CHANGE TO 3000 LB. COUPLING.; ADDED -S6 OPTION

KENCO ENGINEERING COMPANY TULSA, OKLAHOMA		
POT, CALIBRATION (OUTLINE) MODEL NO. 15852		
DATE: 11-21-91	SHEET: 1 OF 2	DRAWING NUMBER
DRN. BY: RC	CHKD. BY:	C-15852
SCALE: NONE	REVISION: D	