

KENCO ENGINEERING COMPANY

P.O. BOX 470426 TULSA, OK 74147-0426 • PHONE: (918) 663-4406 FAX: (918) 663-4406
www.kenco-eng.com e-mail: info@kenco-eng.com

MODEL KUST ULTRASONIC SWITCH INSTALLATION / OPERATION INSTRUCTIONS

GENERAL DESCRIPTION

The KUST Series Ultrasonic Level Switches are ideal, low cost solutions for many liquid level control applications. They operate in a wide variety of services.

PRINCIPLE OF OPERATION

Ultrasonic switches use piezoelectric crystals to transform electrical energy into mechanical motion (sound). The Transmit Crystal sends a pulse of sound through the space between the crystals, to the Receive Crystal. If the space is filled with air, gas, or vacuum, the Receive Crystal does not detect the sound pulse. However, if the space is filled with liquid, **any liquid**, the pulse is detected by the Receive Crystal, and the switch output changes.

MODEL DESCRIPTION

MODEL KUSG / KUST

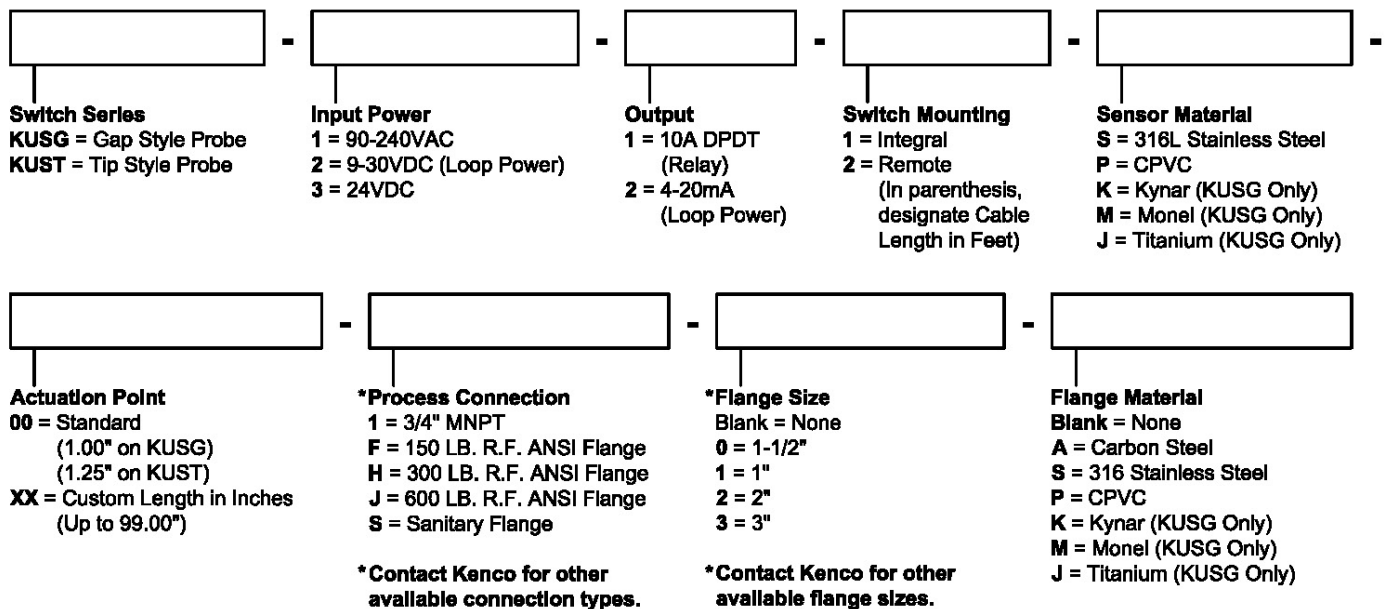

Example Order Number: KUST-3-1-1-S-00-1

INSTALLATION

Unpack the switch carefully. Inspect all units for damage. Report any damage to carrier immediately. Check the contents against the packing slip and purchase order.

Kenco's Ultrasonic Switches are manufactured to the highest quality standards. These switches use electronic components that can be damaged by static electricity. Make sure that you are properly grounded before starting installation. Insure that all electrical connections are properly made, and that there are no "floating" connections.

Operational Check

Before installing the switch a simple operational check should be performed, as follows:

1. Fill a container with water
2. Open the electronics housing cover and connect power (see section on "**Wiring**").
3. Set the Fail Safe jumper to the LLFS position (lower two pins).
4. Apply power
5. Place the sensor gap into the water.
 - a. Relay Version -- The relay will energize (the contacts between (NC) and (C) should open).
 - b. 2-wire Version -- The current in the Positive lead will be 20.0mA.
6. Remove the sensor from the liquid.
 - a. Relay Version -- The relay will de-energize (the contacts between (NC) and (C) should close).
 - b. 2-wire Version -- The current in the Positive lead will be 4.0mA.
7. Disconnect the wiring.

Mounting

For threaded process connections, screw sensor into the opening using a wrench on the sensor mounting nut flats. Use thread tape or suitable pipe compound on the threads. If flanged, bolt the sensor to the mating flange with the proper gasket.

The sensor gap must protrude into the vessel / pipe being measured. The sensor will not function properly if the detection tip is in a nozzle. See the following drawings for mounting guidelines:

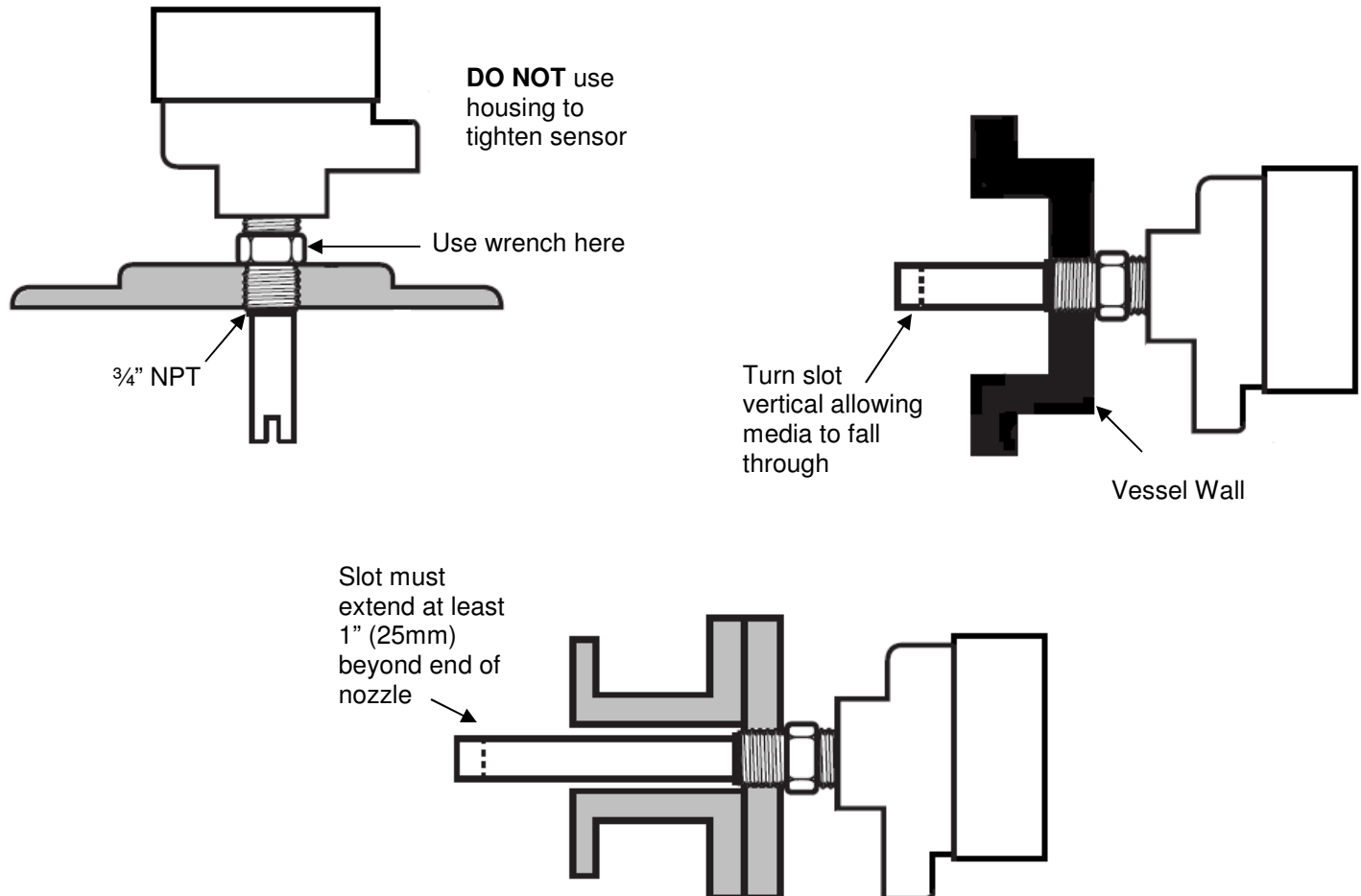

Wiring

It is recommended that conduit be installed onto the 3/4" NPT connection on the electronics housing. A seal drain fitting should be used to prevent moisture from entering the switch. All wiring, conduit, and electrical fittings must conform to local electrical codes for the location selected. If the switch is to be used in a Hazardous Area, the applicable codes of the National Electrical Code must be followed as well.

Relay Version

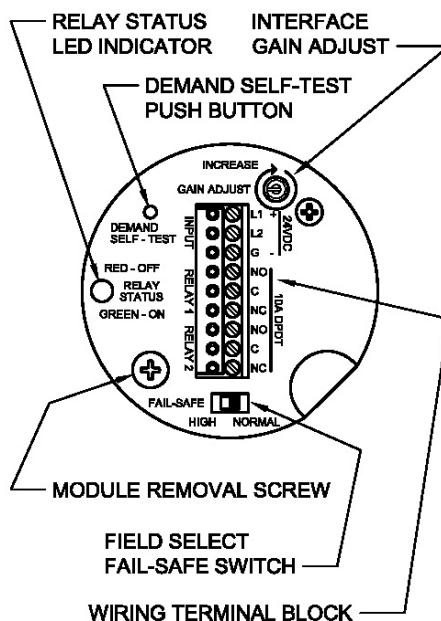

1. Connect power wiring
 - a. AC – Hot (L2), Neutral (L2), and Ground (G)
 - b. DC – Positive (L1), Negative (G)
2. Connect relay wiring (see diagram)
3. Adjust failsafe jumper
 - a. HLFS – top (2) pins
 - b. LLFS – bottom (2) pins

Media Level	Fail Safe Setting	Relay Condition	Relay Terminals NC to C	Relay Terminals NO to C
Above Setpoint	HLFS	De-Energized	Closed	Open
	LLFS	Energized	Open	Closed
Below Setpoint	HLFS	Energized	Open	Closed
	LLFS	De-Energized	Closed	Open

TROUBLESHOOTING

Problem	Solution
No output change with level change	Check wiring; verify that the correct input voltage is applied
	Verify that liquid is filling the sensor gap
	Check for dense foam or dried product in the gap. Switch may not function properly if either condition exists.
	Check sensor phono plugs for a good connection. Unplug and Re-plug each connection.
The output is "chattering"	Check for excessive aeration in process fluid. This is particularly important in viscous fluids.
	Check wiring; verify that the correct input voltage is applied
	Check for turbulence. Relocate switch or isolate from turbulence
	Check for excessive aeration in process fluid. This is particularly important in viscous fluids.