

DIMENSIONAL INFORMATION CHART	
FLANGE SIZE / RATING	DIMENSION "B"
1/2" 150 LB. R.F. PIPE FLANGE	3-5/8"
3/4" 150 LB. R.F. PIPE FLANGE	3-11/16"
1" 150 LB. R.F. PIPE FLANGE	3-3/4"
1-1/2" 150 LB. R.F. PIPE FLANGE	3-7/8"
2" 150 LB. R.F. PIPE FLANGE	3-15/16"

*GAUGE FRAME LENGTH NOTE:
 FRAME LENGTHS GREATER THAN 96"
 REQUIRE MOUNTING PLATES (REFER
 TO B-40344 FOR INSTRUCTIONS)

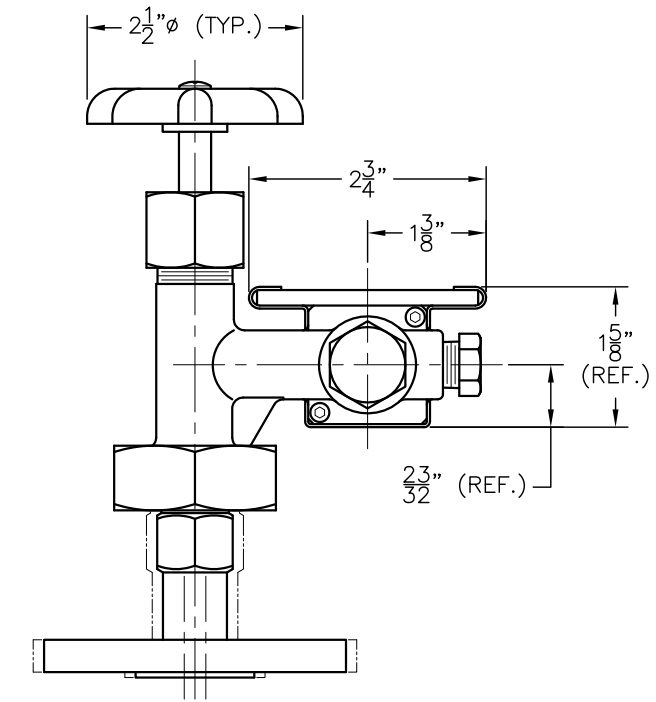
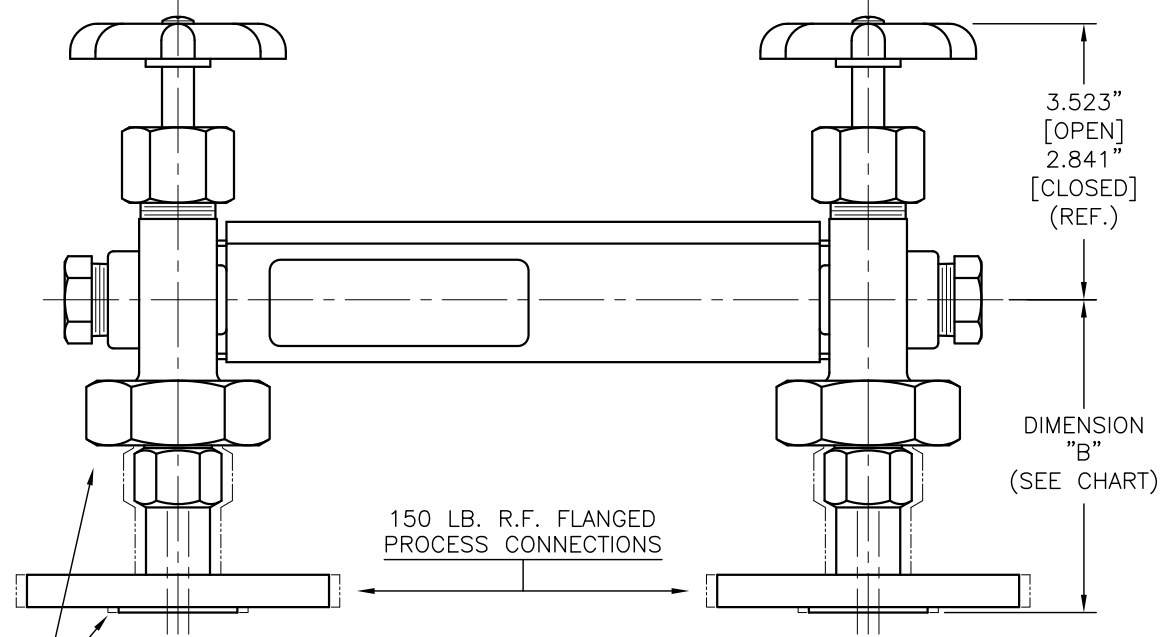

150 LB. R.F. FLANGED
 PROCESS CONNECTIONS

MISALIGNMENT UNIONS WILL ALLOW PROCESS
 CONNECTION CENTER-TO-CENTER DISTANCE
 SPECIFIED BY CUSTOMER TO VARY ±1/4"

INFORMATION IS PROPRIETARY TO KENCO ENGINEERING CO.

REV.	DATE	BY	CHKD.	ECN	EXPLANATION:
B	12-23-03	RDM	DM	N/A	ITEM 14 MATERIAL WAS 18-8 STAINLESS STEEL
C	02-17-05	DS	KI	N/A	RESEQUENCED BOM; ITEM 2 WAS A-43793
D	02-03-10	DS	PAS	N/A	ITEM 11 WAS P-13698; ITEM 19 WAS P-4765; REMOVED P-23998; RESEQUENCED ITEMS 20 THRU 23
E	07-18-11	PAS	DS	000082	ITEM 19 MATERIAL WAS 18-8 STAINLESS STEEL

KENCO ENGINEERING COMPANY TULSA, OKLAHOMA		
DATE: 08-19-02	SHEET: 1 OF 2	DRAWING NUMBER
DRN. BY: DPS	CHKD. BY: RDM	C-43714
SCALE: 7/8"=1"	REVISION: E	