

MODEL 8800-PVC

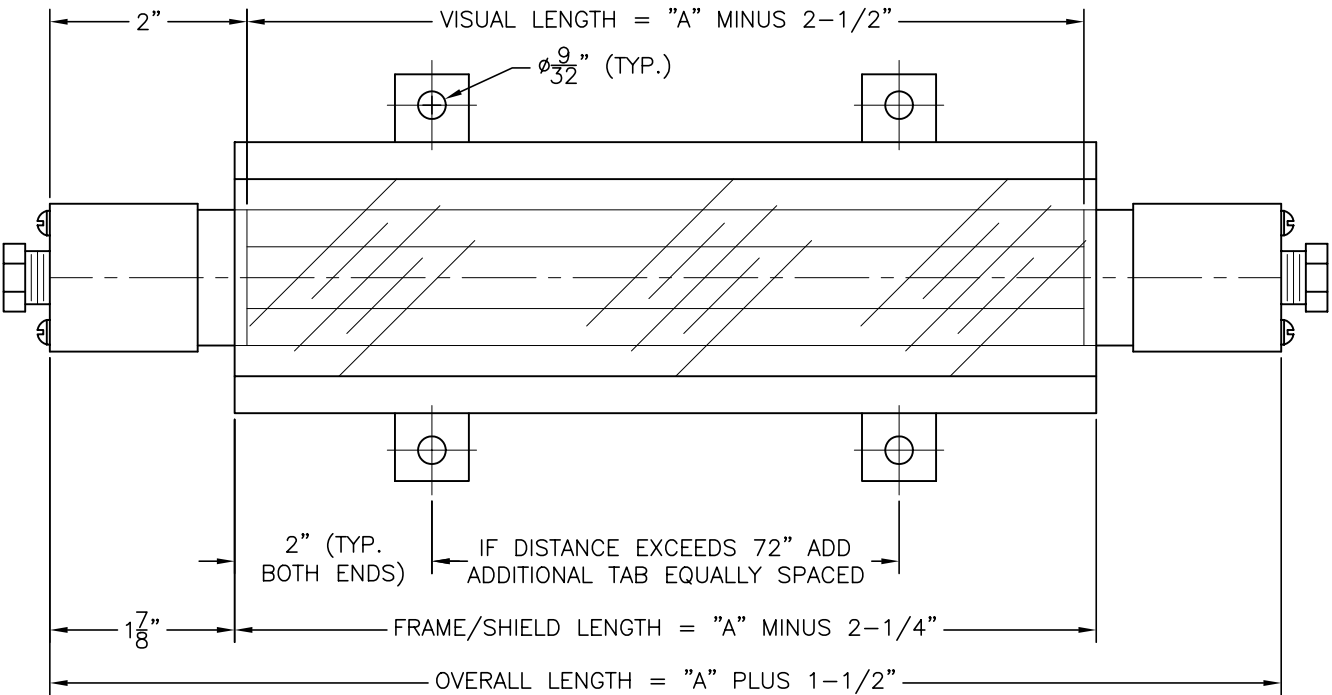

TEMPERATURE: AMBIENT
 PRESSURE: ATMOSPHERIC

WETTED MATERIALS
 PVC END CONNECTIONS
 GLASS SIGHT TUBE

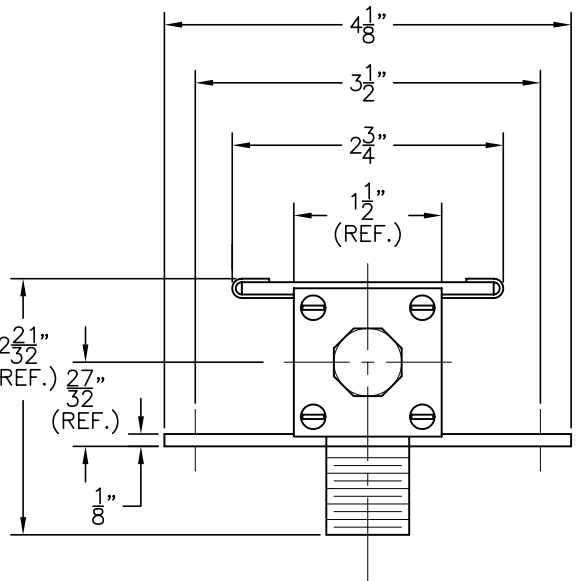
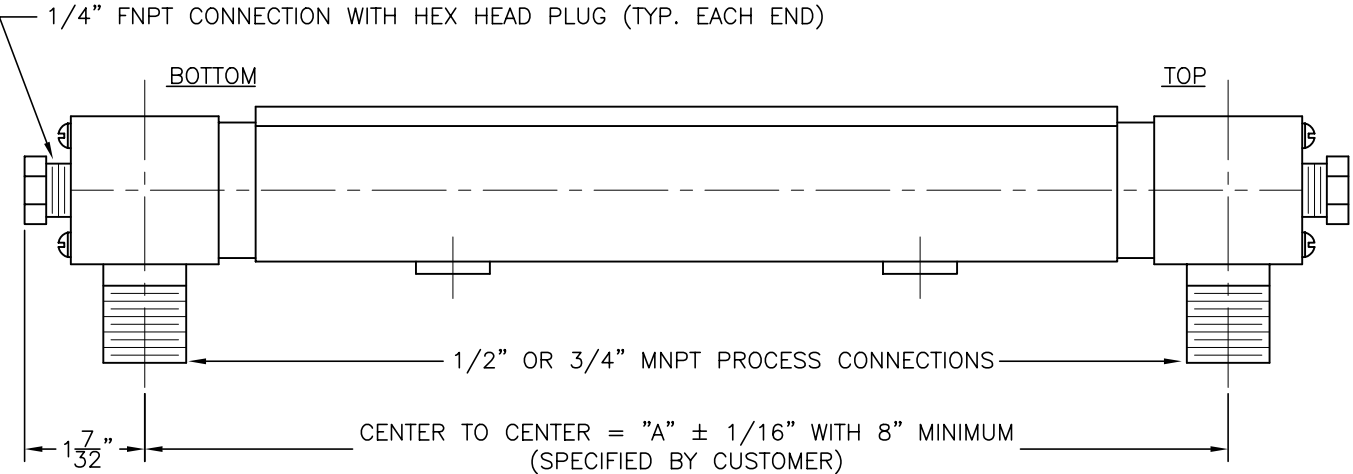

DIMENSION ARE FOR REFERENCE PURPOSES ONLY
 AND ARE SUBJECT TO CHANGE AT ANY TIME WITHOUT
 NOTICE.

COPYRIGHT © 2003-KENCO INTERNATIONAL, INC.-ALL RIGHTS RESERVED

REV.	DATE	BY	ECN	EXPLANATION:

KENCO ENGINEERING COMPANY TULSA, OKLAHOMA		
GAUGE, BULK TANK PUMP SETTING (OUTLINE DRAWING) MODEL 8800-PVC		
DATE: 02-03-03	SHEET: 1 OF 1	DRAWING NUMBER
DRN. BY: DPS	CHKD. BY:	C-44012
SCALE: NONE	REVISION:	