

MODEL 8800-FL

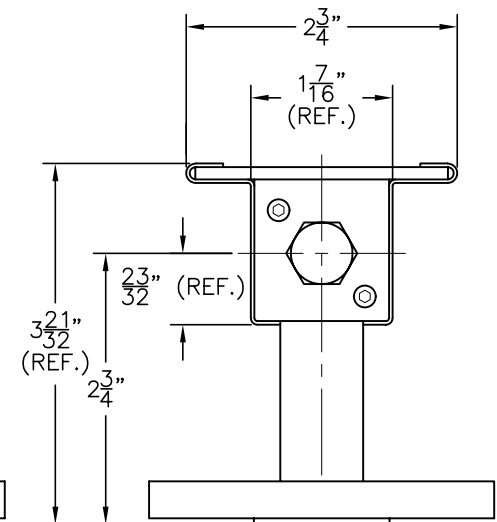
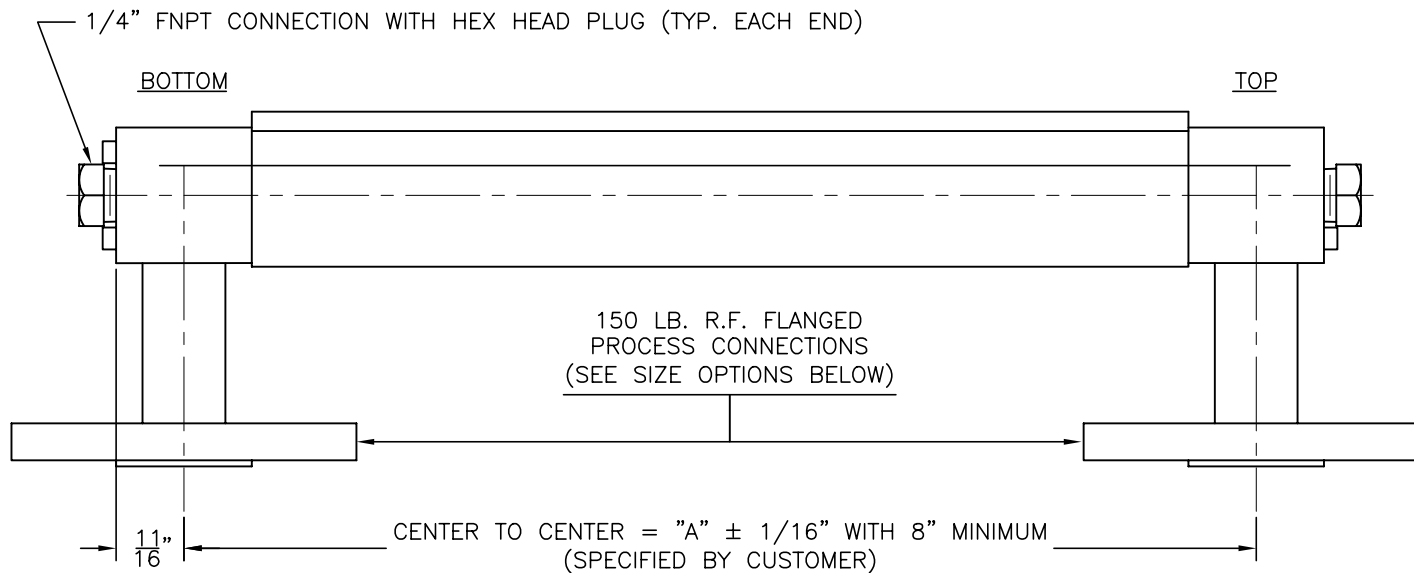
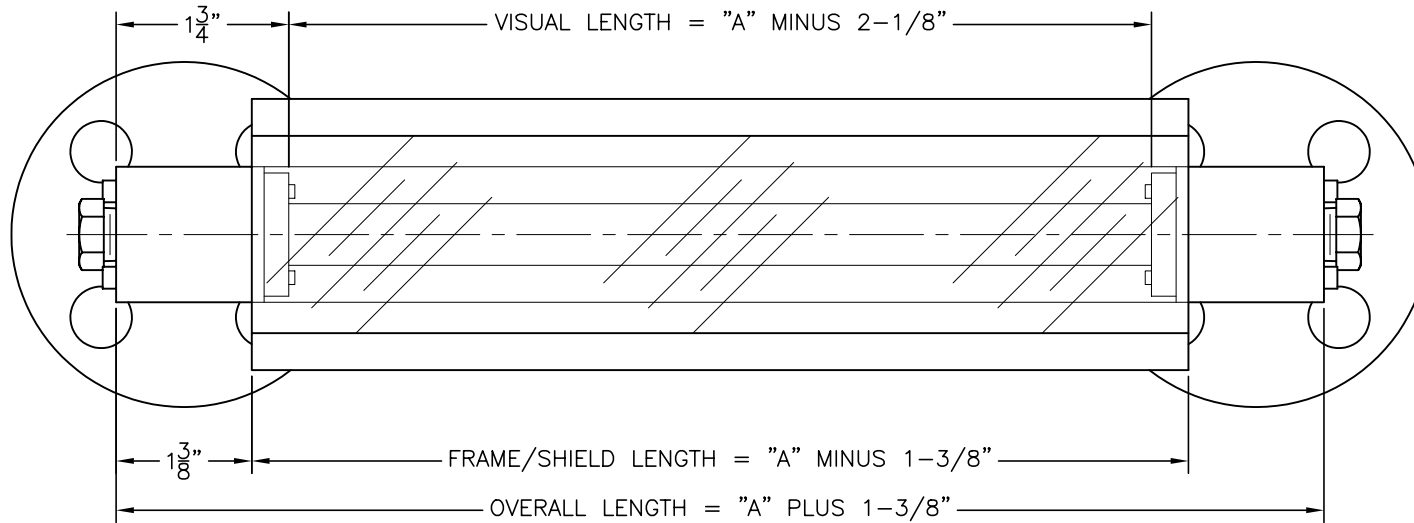

GUAGE MODEL NUMBER / PROCESS CONNECTION SIZE:

- 88FL50 (1/2" 150 LB. R.F. PIPE FLANGE)
- 88FL75 (3/4" 150 LB. R.F. PIPE FLANGE)
- 88FL10 (1" 150 LB. R.F. PIPE FLANGE)
- 88FL15 (1-1/2" 150 LB. R.F. PIPE FLANGE)
- 88FL20 (2" 150 LB. R.F. PIPE FLANGE)

DIMENSION ARE FOR REFERENCE PURPOSES ONLY AND ARE SUBJECT TO CHANGE AT ANY TIME WITHOUT NOTICE.

COPYRIGHT © 2003-KENCO INTERNATIONAL, INC.-ALL RIGHTS RESERVED

REV.	DATE	BY	ECN	EXPLANATION:

KENCO ENGINEERING COMPANY TULSA, OKLAHOMA		
GAUGE, BULK TANK PUMP SETTING (OUTLINE DRAWING) MODEL 8800-FL		
DATE: 02-03-03	SHEET: 1 OF 1	DRAWING NUMBER
DRN. BY: DPS	CHKD. BY:	C-44009
SCALE: NONE	REVISION:	