

**KENCO 16, 30 AND 55 GALLON TANKS WITH SIGHT TUBE ISOLATION VALVE
(ILLUSTRATIONS)**

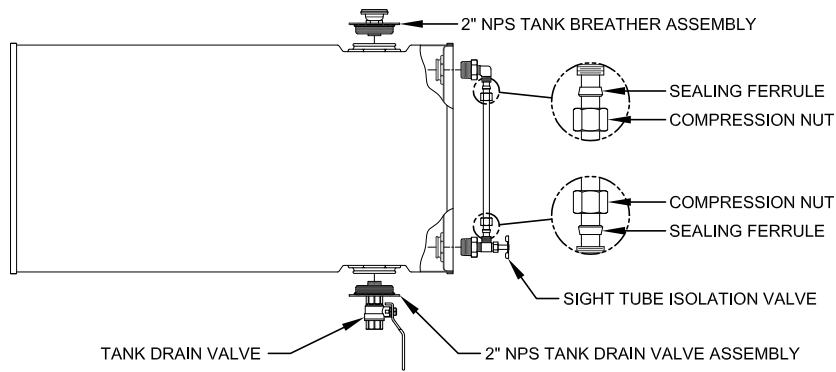

MODEL K16G-IV, K30G-IV & K55G-IV

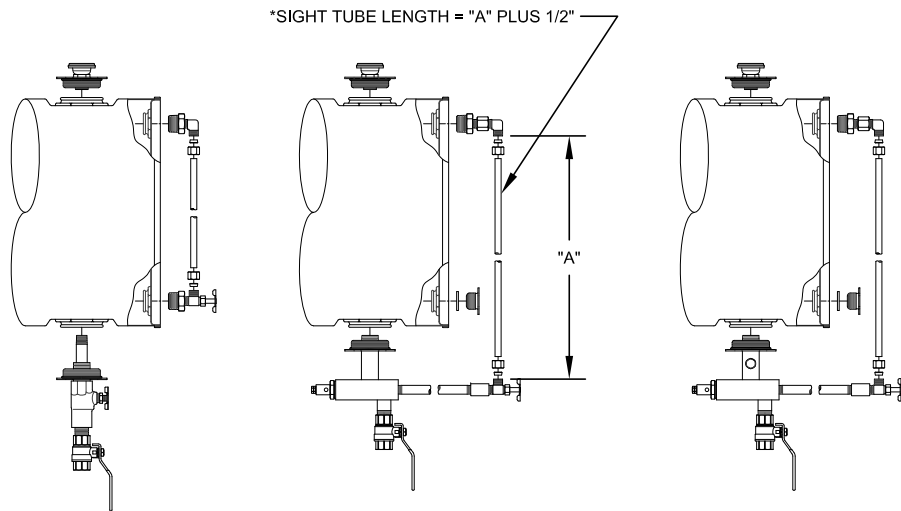

**MODEL
K16G-IV, K30G-IV & K55G-IV
WITH "-CD" OPTION**

**MODEL
K16G-IV, K30G-IV & K55G-IV
WITH "-FS" OPTION**

**MODEL
K16G-IV, K30G-IV & K55G-IV
WITH "-FS-CD" OPTION**

*MAKE SURE SIGHT TUBE IS CUT SQUARE AND IS FREE OF ANY BURRS. A PROPERLY CUT SIGHT TUBE SHOULD HAVE 1/16" TO 1/8" OF PLAY AFTER INSTALLATION.

**KENCO 16, 30 AND 55 GALLON TANKS WITH SIGHT TUBE ISOLATION VALVE
(ASSEMBLY INSTRUCTIONS)**

1. KENCO TANKS SHIP WITH A TANK KIT CONTAINING ALL THE PARTS NECESSARY TO ASSEMBLE THE MODEL OPTION ORDERED. SEE ILLUSTRATIONS ON LEFT-HAND SIDE OF SHEET FOR VARIOUS MODEL CONFIGURATIONS.
2. MAKE SURE TANK IS THE SIZE ORDERED.
3. MAKE SURE TANK KIT CONTAINS THE PARTS REQUIRED TO BUILD THE TANK MODEL OPTION REQUESTED (EXAMPLES: K16G-IV-TK, K16G-CD-IV-TK, K16G-FS-IV-TK AND K16G-FS-CD-IV-TK).
4. REMOVE THE EXISTING TANK PORT THREADED PLUGS.
5. INSTALL 2" NPS TANK DRAIN VALVE ASSEMBLY.
NOTE: 2" NPS DRUM PLUG IS EQUIPPED WITH A SEAL THAT DOES NOT REQUIRE AN EXCESSIVE AMOUNT OF TORQUE TO ACHIEVE A POSITIVE SEAL.
6. PREPARE TANK KIT PARTS HAVING NPT MALE PIPE THREADS FOR INSTALLATION BY WRAPPING THEM WITH PTFE TAPE SUPPLIED WITH TANK KIT.
NOTE: TANK KITS FOR "-FS" AND "-FS-CD" MODELS CONTAIN A 3/4" NPS METAL DRUM PLUG AND GASKET TO INSTALL INTO THE LOWER PORT ON FRONT FACE OF TANK. PLUG DOES NOT REQUIRE ANY THREAD SEALANT AND GASKET DOES NOT REQUIRE AN EXCESSIVE AMOUNT OF TORQUE TO ACHIEVE A POSITIVE SEAL.
7. INSTALL SIGHT TUBE CONNECTION(S) INTO TANK WITH SIGHT TUBE PORTS FACING EACH OTHER AS SHOWN IN ILLUSTRATIONS.
8. REMOVE COMPRESSION NUT AND SEALING FERRULE FROM UPPER AND LOWER SIGHT TUBE CONNECTIONS.
9. PREPARE TO INSTALL SIGHT TUBE.
NOTE: DUE TO VARIATIONS IN PIPE THREAD ENGAGEMENT ON "-FS" AND "-FS-CD" MODELS, THE SIGHT TUBE SUPPLIED WILL HAVE TO BE CUT TO THE PROPER LENGTH USING A TUBING CUTTER OR A SAW. SEE "-FS" ILLUSTRATION FOR CUTTING LENGTH FORMULA.
10. INSTALL SIGHT TUBE WITHOUT COMPRESSION NUTS OR SEALING FERRULES INTO UPPER OR LOWER SIGHT TUBE CONNECTION AND BEND AS REQUIRED TO INSTALL INTO CONNECTION ON OPPOSITE END.
NOTE: SIGHT TUBE SHOULD HAVE 1/16" TO 1/8" OF PLAY AFTER INSTALLATION.
11. AFTER FINAL CONFIRMATION THAT SIGHT TUBE LENGTH IS CORRECT, REMOVE SIGHT TUBE AND SLIDE COMPRESSION NUTS AND SEALING FERRULES OVER THE ENDS OF THE SIGHT TUBE AS SHOWN.
NOTE: IT IS IMPORTANT THAT THE SMALL END OF THE TAPERED SEALING FERRULE BE ORIENTED AS SHOWN IN ILLUSTRATIONS.
12. REINSTALL SIGHT TUBE AND TIGHTEN COMPRESSION NUTS 1/4 TO 1/2 TURN BEYOND HAND TIGHT TO ACHIEVE A POSITIVE SEAL.
13. MOUNT TANK IN A HORIZONTAL POSITION WITH TANK DRAIN VALVE ON BOTTOM AS REQUIRED FOR YOUR APPLICATION.
14. MAKE SURE TANK DRAIN VALVE IS IN THE CLOSED POSITION.
15. MAKE SURE THE SIGHT TUBE ISOLATION VALVE IS IN THE OPEN POSITION.
16. FILL TANK WITH OIL FOR YOUR SERVICE THROUGH 2" NPS PORT ON TOP OF TANK AND CHECK FOR LEAKS.
17. TIGHTEN UP ANY CONNECTIONS THAT EXHIBIT ANY SIGN OF A LEAK.
18. INSTALL 2" NPS TANK BREATHER ASSEMBLY ON TOP OF TANK.
NOTE: 2" NPS DRUM PLUG IS EQUIPPED WITH A SEAL THAT DOES NOT REQUIRE AN EXCESSIVE AMOUNT OF TORQUE TO ACHIEVE A POSITIVE SEAL.
19. INSTALL TANK DRAIN VALVE PIPING AS REQUIRED FOR YOUR APPLICATION.
20. OPEN TANK DRAIN VALVE TO CHECK PIPING FOR LEAKS AND TO PUT TANK INTO SERVICE.

SIGHT TUBE REPLACEMENT INSTRUCTIONS

1. MAKE SURE YOU HAVE THE CORRECT SIGHT TUBE REPAIR KIT (EXAMPLES: K16G-RK AND K16G-FS-RK).
2. CLOSE THE SIGHT TUBE ISOLATION VALVE.
3. MAKE SURE OIL LEVEL IN TANK IS BELOW THE TOP OF VISUAL INDICATION IN SIGHT TUBE.
4. COMPLETELY LOOSEN SIGHT TUBE COMPRESSION NUTS.
5. REMOVE SIGHT TUBE, COMPRESSION NUTS AND SEALING FERRULES.
6. REPLACE EXISTING SIGHT TUBE AND SEALING FERRULES WITH NEW ONES SUPPLIED BY KENCO.
7. FOLLOW STEPS 9 THROUGH 12 ABOVE FOR PROPER INSTALLATION.
8. OPEN THE SIGHT TUBE ISOLATION VALVE.
9. CHECK SIGHT TUBE CONNECTIONS FOR LEAKS.
10. TIGHTEN COMPRESSION NUTS SLIGHTLY TO STOP LEAK IF REQUIRED.



P.O. Box 470426 -- Tulsa, Oklahoma 74147
Phone: 918-663-4406 -- Fax.: 918-663-4480
www.kenco-eng.com -- E-mail: info@kenco-eng.com

A-62916
(REV. #)
[05-24-11]