

# KENCO ENGINEERING COMPANY

P.O. BOX 470426 TULSA, OK 74147-0426 • PHONE: (918) 663-4406 FAX: (918) 663-4480  
[www.kenco-eng.com](http://www.kenco-eng.com) e-mail: [info@kenco-eng.com](mailto:info@kenco-eng.com)

## SERIES KTD THERMAL DIFFERENTIAL FLOW/LEVEL SWITCH INSTALLATION / OPERATION INSTRUCTIONS

### TABLE OF CONTENTS

1. GENERAL DESCRIPTION .....	2
2. PRINCIPLE OF OPERATION .....	2
3. MODEL DESCRIPTION .....	2
4. INSTALLATION .....	3
5. WIRING CONNECTIONS.....	4
6. OPERATIONAL CHECK.....	5
7. PRE-CALIBRATION .....	5
8. CALIBRATION (Level Switch).....	6
9. CALIBRATION (Flow Switch).....	7
10. MAINTENANCE & TROUBLESHOOTING .....	8
11. SPECIFICATIONS .....	8

## GENERAL DESCRIPTION

The Series KTD Thermal Differential Switch is the state-of-the-art in gaseous and liquid flow switching or liquid level / interface control. Flow or level detection is accomplished by using a high resolution **thermal differential** technique. The standard sensor wetted parts are of durable 316L series stainless steel, all welded construction with no moving parts. The switch is easy to install and adjust, giving reliable, low maintenance performance in the most demanding applications.

## PRINCIPLE OF OPERATION

The Series KTD Thermal Differential Switch uses a thermal differential technique to measure liquid level or interface by sensing changes in the thermal heat transfer characteristics of the media where it is located. The sensor consists of a pair of matched Resistance Temperature Detectors (RTD's) encased in twin 316 series, stainless steel tubes. One RTD is self-heated using a constant DC current. The other sensor is unheated and provides an accurate ambient process temperature reference. The thermal differential created between the heated and reference RTD pair is a function only of the media with which the sensor is in contact. The differential is greatest when no liquid is present (dry condition) and decreases as liquid quenches the switch sensors (wet condition).

Hydrocarbons generally have lower heat-transfer characteristics than aqueous-based materials so liquid-liquid interface detection is possible. In general, any two media will exhibit some difference in heat-transfer characteristics. Thus, the switch can be calibrated to detect the interface between two immiscible liquids.

This switch can also be used as a no-flow or a low flow switch. In this case the actual flow of the liquid or gas provides the cooling effect. In other words, the lower the flow rate the greater the temperature differential between the (2) RTD's.

Solid-state electronics transform the temperature differential into a voltage that is compared to a control voltage to actuate a relay and indicate a change in state (wet vs. dry). The instrument head at the top of the unit contains the Switch electronics board which is easily removable from the instrument head so that field wiring can be connected to the field terminal block.

## MODEL DESCRIPTION

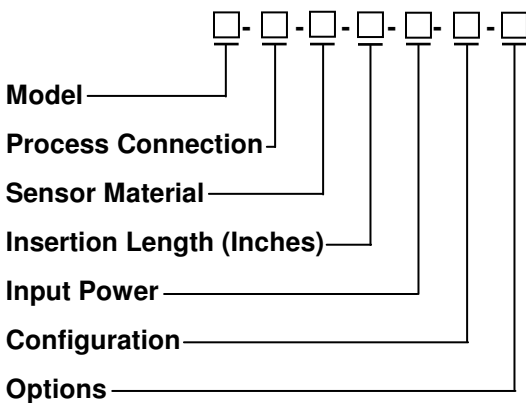

### Model

Description	Code
Level Switch	KTDL
Flow Switch	KTDF

### Sensor Material

Description	Code
316L SS	S6
304 SS	S4
304L SS	SL
Hastelloy-B	HB
Hastelloy-C	HC
Inconel 600	IO
Monel	MN
Alloy-20	A2
Special Material	SM

### Process Connection

Description	Code
1/2" NPT	050
3/4" NPT	075
1" NPT	100
1 1/2" Sanitary	3A1
1" 150# ANSI Flange	RA1
2" 150# ANSI Flange	RA2
1" 300# ANSI Flange	RB1
2" 300# ANSI Flange	RB2
Low Flow Sensor	LFS
Special Connection	SPL

### Input Power

Description	Code
110 Vac	110
220 Vac	220
24 Vdc	24D
24 Vac	24A

### Configuration

Description	Code
Integral Mounting	LE
Remote Mounting	RE

### Insertion Length

002.00 (standard)  
000.50 – 120.00 (optional)

### Options

Description	Code
No Options	00
RTD Output	RT
Live Tap	LT
CE Approved	CE

### Options (cont.)

Description	Code
Extended Neck	EN
*High Temp (850°F)	HT
*Medium Temp (572°F)	MT
Explosion-proof Window	XW

\* Remote Mounting Required

### Options (cont.)

Description	Code
Additional Cable	CA
Variable Insertion	VI
Factory Calibration	CB
Thermocouple Output	TO

### Options (cont.)

Description	Code
SS Tag	TG
Sensor Installed in Tee	TE

## INSTALLATION

Unpack the switch carefully. Inspect all units for damage. Report any damage to carrier immediately. Check the contents against the packing slip and purchase order.

Kenco's Thermal Differential Flow / Level Switches are manufactured to the highest quality standards. These instruments use electronic components that can be damaged by static electricity. Make sure that you are properly grounded before starting installation. Insure that all electrical connections are properly made, and that there are no "floating" connections.

### **Mechanical Installation**

The Series KTD Switches have a 3/4" NPT (standard) process connection. When used as a level / interface switch, and horizontally mounted, the sensor must be oriented so that the RTD's are parallel with the liquid surface. When used as a flow switch the sensor must be oriented so that the RTD's are perpendicular with the flow direction.

Use a 1-1/8" open end wrench to tighten the sensor in the process connection. Use the hex flats on the sensor for tightening. DO NOT use the instrument housing for tightening. Rotation of the instrument housing in respect to the sensor can cause internal wiring damage, and will void the warranty.

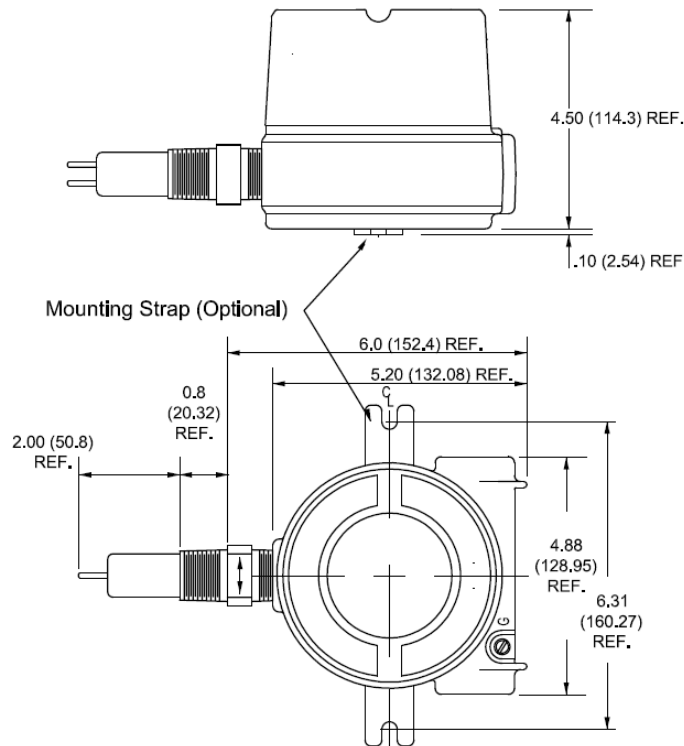
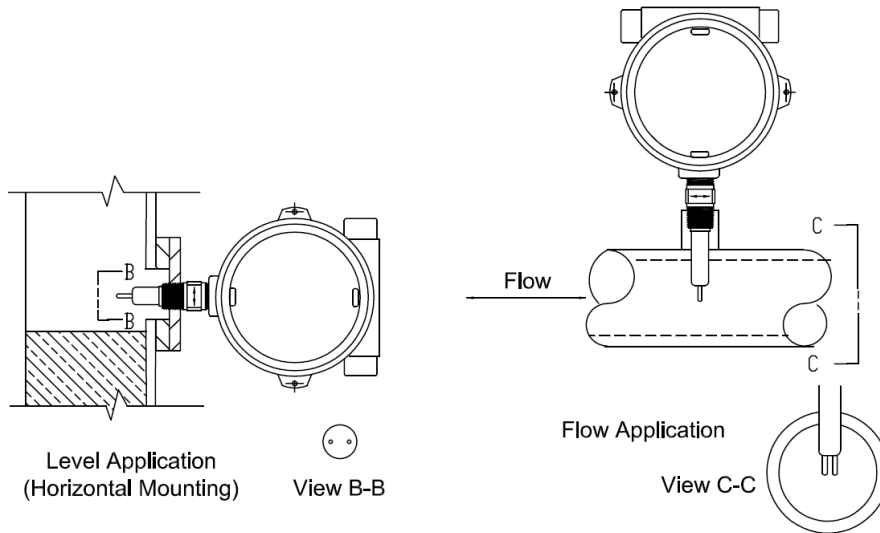

Dimensions in Inches (mm)

**Electrical Installation**

It is recommended that conduit be installed onto the 3/4" NPT connection on the electronics housing. A seal drain fitting should be used to prevent moisture from entering the switch. In high humidity areas, use a breather drain to minimize moisture intrusion

All wiring, conduit, and fittings must conform to local electrical codes for the location selected. If the transmitter is to be used in a Hazardous Area, the applicable sections of the National Electric Code must be followed as well.

**WIRING CONNECTIONS**

Before starting installation procedures in hazardous areas, insure that all power sources have been turned off and locked out. "Live" electrical circuits can ignite flammable gasses and dusts.

1. Remove the cover from the instrument enclosure.
2. Loosen the (2) screws holding the electronics module in place. These are spring-loaded captive screws. They will pop-up when loosened sufficiently. Remove the electronics module from the instrument enclosure.
3. Hold the module firmly around the transformer and pull it out of the enclosure. No tools are necessary to remove the module.

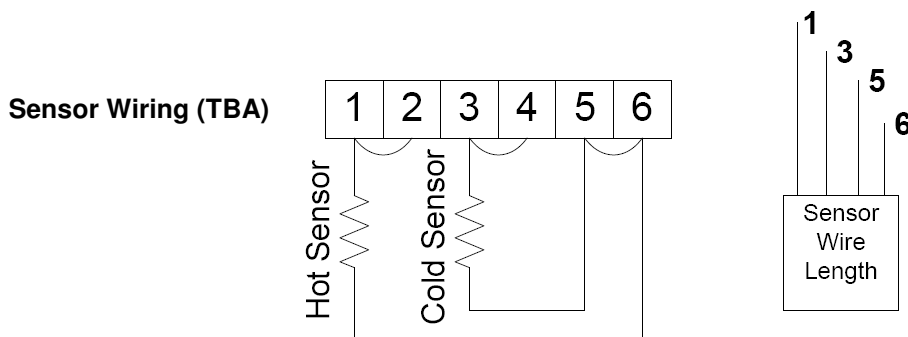
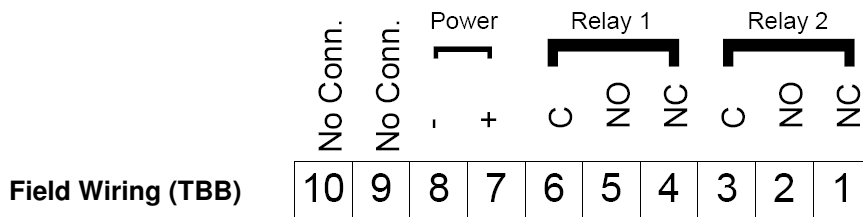
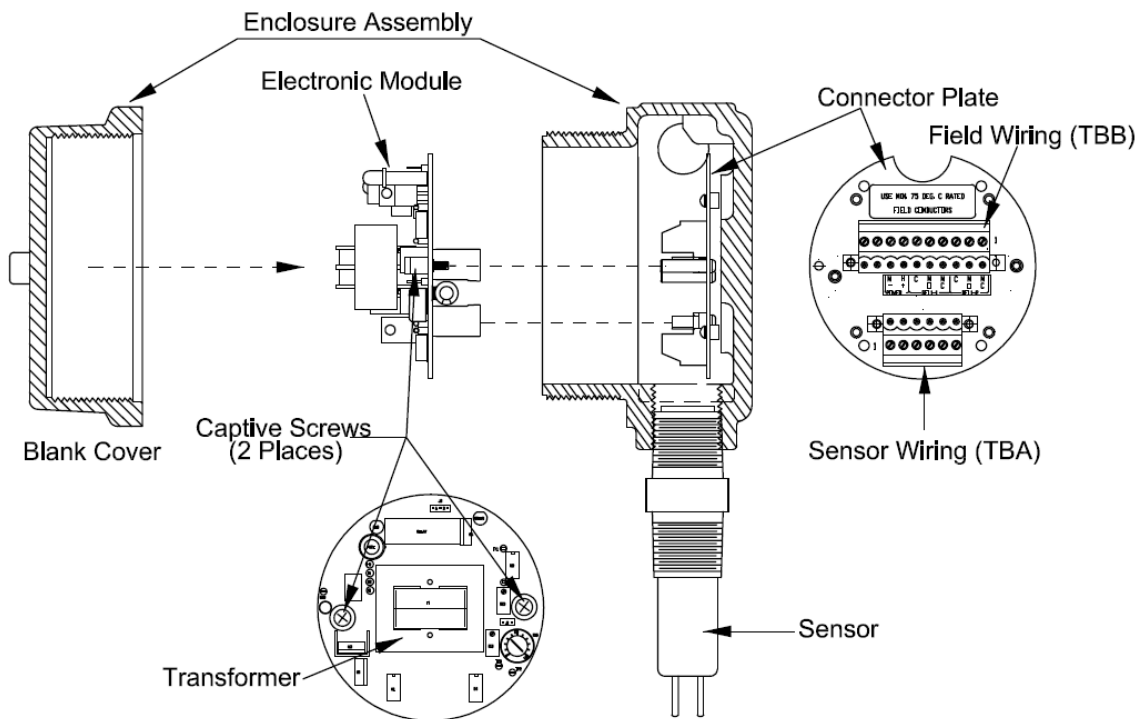

4. Pull the power/signal wires through the conduit opening.
5. Connect Power and relay wiring to Terminal Block (TBB) see figure on previous page.
6. Reinstall the Electronic Module and tighten the (2) captive screws.
7. Reinstall the Instrument Enclosure cover.

**OPERATIONAL CHECK**

After the switch is installed, and the level is below the sensor or there is no flow, perform the following test procedure to insure proper function.

1. Remove the Instrument Enclosure Cover.
2. Apply power.
3. Verify that either the Red or Green LED is illuminated.
4. If neither LED is on, refer to the Troubleshooting section.

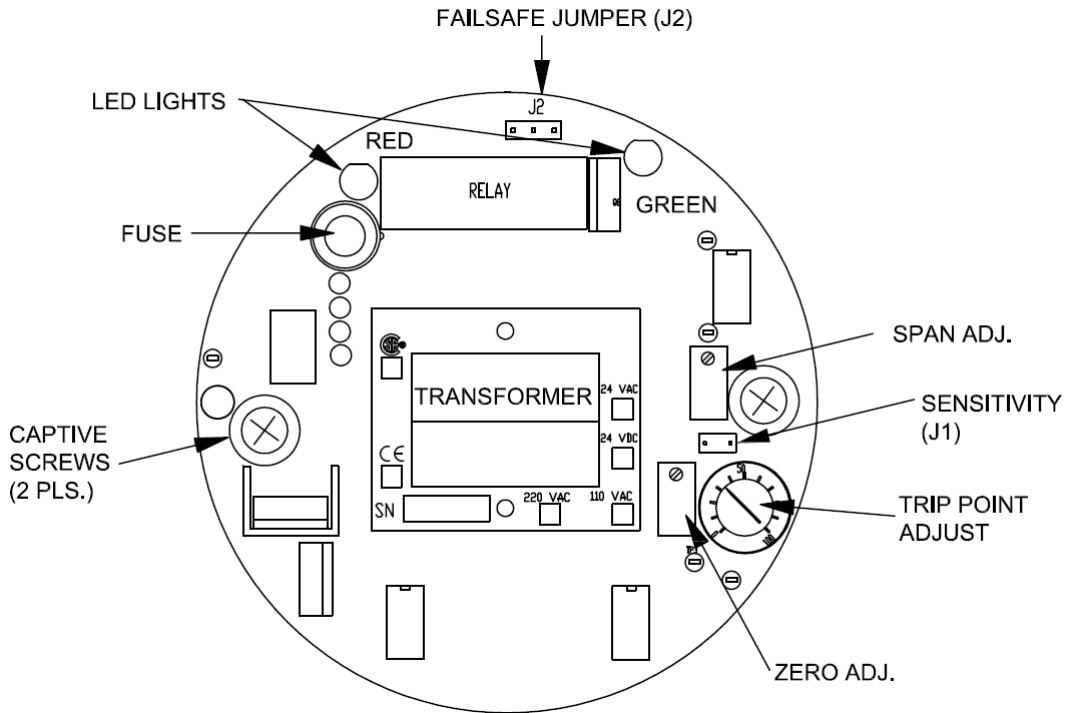

**PRE-CALIBRATION**

**LED States**

The Red and Green LED's indicate the status of the sensor, and are independent of the relay status. When the Red LED is illuminated, this indicates a Dry (Level) or No/Low (Flow) condition. When the Green LED is illuminated, a Wet (Level) or High (Flow) condition is indicated.

**Jumper Settings**

There are (2) jumpers that must be set prior to calibration:

J1 – Model KTDL – There is no J1 Jumper or Pins

Model KTDF – Leave the Jumper in place for Flow Applications; Remove the Jumper if you decide to use this model for a Level / Interface Application

J2 – This sets the Failsafe condition of the switch. The jumper should cover the (2) left-most pins for High Level Failsafe (HLFS) condition, or the (2) right-most pins for Low Level Failsafe (LLFS) condition. See the table below for the comparison of the two conditions, as well as the condition of the Red and Green LED's.

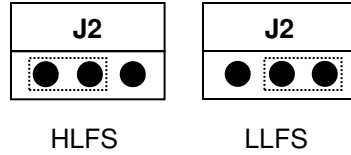

Sensor Status	Red LED	Green LED	Fail Safe Setting	Relay Condition	Relay Terminals NC to C	Relay Terminals NO to C
Wet (Level) or High Flow	Off	On	HLFS	De-Energized	Closed	Open
			LLFS	Energized	Open	Closed
Dry (Level) or Low/No Flow	On	Off	HLFS	Energized	Open	Closed
			LLFS	De-Energized	Closed	Open

**CALIBRATION (Level Switch)**  
(Refer to Page #5 for location of controls)

**NOTE: For optimum performance, the calibration must be done at actual process temperature.**

1. Remove the Instrument Enclosure Cover

2. Ensure that the level is below the sensor tips, and that the tips are dry.

3. Apply power. Allow the sensor to warm-up for five minutes.

4. Set the "Trip Point Adjust" pot to "0" (fully counterclockwise).

5. Set the "Zero Adjust" pot so that the Red LED just does illuminate. This is a 25-turn pot. If the Green LED is on, turn the pot counterclockwise. If the Red LED is on, turn the pot clockwise.

6. Toggle the "Zero Adjust" pot back and forth until the trip point is well defined. Leave the Red LED illuminated.

7. Raise the level of the liquid in the vessel until the sensor tips are covered.

8. Set the "Trip Adjust" pot to 100 (fully clockwise).

9. Set the "Span Adjust" pot so that the Green LED just does illuminate. This is a 25-turn pot. If the Green LED is on, turn the pot clockwise. If the Red LED is on, turn the pot counter clockwise.

10. Toggle the "Span Adjust" pot back and forth until the switching point is well defined. Leave the Green LED illuminated.

11. Set the "Trip Point Adjust" pot to 80 and the calibration is complete. Setting this pot to 80 gives an approximate equal trip time from wet-to-dry and dry-to-wet. Setting this pot closer to "0" will speed up the dry-to-wet time, and slow down the wet-to-dry time. Setting this pot closer to "100" will slow down the dry-to-wet time, and speed up the wet-to dry time.

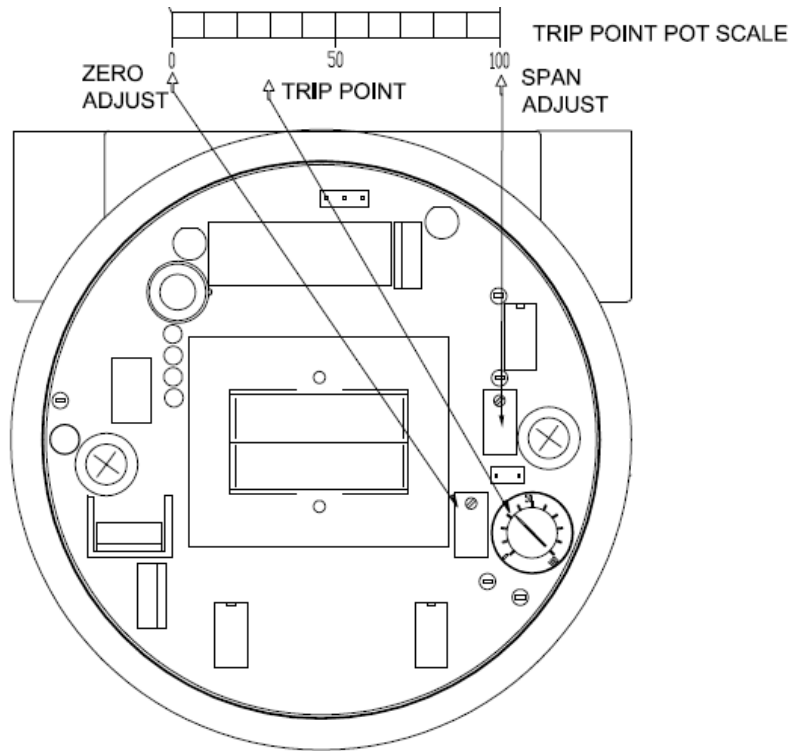

## CALIBRATION (Flow Switch)

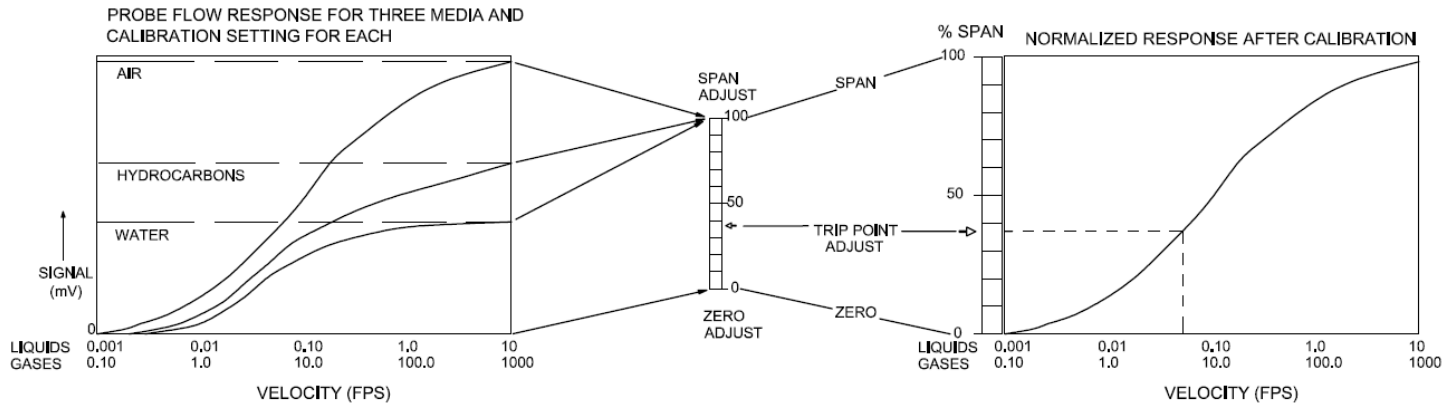

(Refer to Page #5 for location of controls)

**NOTE: For optimum performance, the calibration must be done at actual process temperature and pressure conditions in gasses, or actual process temperature in liquids.**

**NOTE: The sensor tips must be perpendicular to the flow direction (see Page #3 – View C-C)**

1. Remove the Instrument Enclosure Cover
2. Ensure that the pipeline is filled with fluid and at no or minimum flow.
3. Apply power. Allow the sensor to warm-up for five minutes.
4. Set the "Trip Point Adjust" pot to "0" (fully counterclockwise).
5. Set the "Zero Adjust" pot so that the Red LED just does illuminate. This is a 25-turn pot. If the Green LED is on, turn the pot counterclockwise. If the Red LED is on, turn the pot clockwise.
6. Toggle the "Zero Adjust" pot back and forth until the trip point is well defined. Leave the Red LED Illuminated.
7. Adjust the liquid or gas flow to maximum velocity for the application. Insure that the flow is homogenous, constant, and if a liquid – free of bubbles. **NOTE: The maximum allowable flow rate for the unit is 2.5ft/sec (aqueous liquid), 5 ft./sec (hydrocarbon liquid) or 500ft./sec (gases).**
8. Set the "Trip Adjust" pot to 100 (fully clockwise).
9. Set the "Span Adjust" pot so that the Green LED just does illuminate. This is a 25-turn pot. If the Green LED is on, turn the pot clockwise. If the Red Led is on, turn the pot counter clockwise.
10. Toggle the "Span Adjust" pot back and forth until the switching point is well defined. Leave the Green Led illuminated.
11. If the switch is to be used for flow – no flow, set the "Trip Adjust" pot to 50 and go to Step #14. **NOTE: This adjustment can be set for tripping points between 10% and 90% of the span from no flow to maximum flow).**
12. A more exact flow rate setting may be made by establishing the flow at the desired rate with a separate flow meter and proceeding to Step #13.
13. Adjust the "Trip Adjust" pot to obtain a trip point as exhibited by the LED Status Lights. If trip on decreasing flow is desired, set for Red Illumination. If a trip on increasing flow is desired, set for Green Illumination.
14. Verify that the switch will reset by returning the actual product flow to maximum or minimum flow rates. The calibration is complete.

## MAINTENANCE & TROUBLESHOOTING

The sensor can be cleaned by soaking, spraying or ultrasonic cleaning. Verify material compatibility before using any strong solvent or acid on the sensor. DO NOT sandblast or scour the sensor with abrasives. The sensor could be damaged by this process.

### TEST #1 - Power & Continuity Check

1. Remove power.
2. Remove Instrument Enclosure cover.
3. Loosen (2) Captive Screws (see Page #4)
4. Remove Electronic Module by grasping the Transformer, and pulling straight out.
5. Apply power. Verify the correct voltage at pins 7 (+ for DC) & 8 (- for DC) of Terminal Block TBB.
6. If the voltage is correct, remove power and check the fuse (F1 – see Page #5). If the fuse is bad, replace it with the appropriate fuse.
7. If the fuse is OK, proceed to the Functionality Check.

### TEST #2 - Functionality Check (Perform TEST #1 first)

1. Remove power.
2. Allow a 5 minute cool-down period.
3. Measure the resistance of each RTD (Terminal Block TBA).
  - a. Measure the resistance between Pins 1 & 6 – (First RTD).
  - b. Measure the resistance between Pins 3 & 5 – (Second RTD).
4. The resistance values for Step #3 should be  $110\Omega \pm 10\Omega @ 70^{\circ}\text{F}$ . Also, they must be within 5% of each other.
5. Measure the resistance between Pin #1 of Terminal Block TBA and the Instrument Enclosure. It should be greater than 20Meg Ohms.
6. If the resistance values are not as specified above, the sensor must be replaced.
7. If the resistance values are correct, the Electronics Module must be replaced.

## SPECIFICATIONS

Description		Specification
Power Supply	AC	110Vac or 220Vac @ 50/60 Hz
	DC	24Vdc
Output		5A DPDT – Failsafe is field selectable
Temperature Range (Electronics)		-40°F to 140°F (-40°C to 60°C)
Temperature Range (Sensor)	Standard	-100°F to 390°F (-70°C to 200°C)
	Medium Temp.	-100°F to 572°F (-40°C to 300°C)
	High Temp.	-100°F to 850°F (-40°C to 458°C)
Pressure Range		Atmospheric to 3000psig
Operating Range (Flow)	Aqueous Liquids	0.01 – 2.5 feet/second
	Hydrocarbon Liquids	0.01 – 5.0 feet/second
	Gasses	0.1 – 500 feet/second
Response Time		0.5 to 5.0 seconds (media dependent)
Stability		<0.5% from calibrated setpoint over a range of $\pm 50^{\circ}\text{F}$
Repeatability		$\pm 1.0\%$